

## 1. Product Description

Nexto Series is a powerful and complete Programmable Logic Controller (PLC) Series with unique and innovative features. Due to its flexibility, smart design, enhanced diagnostics capabilities and modular architecture, Nexto PLC can be used for control systems in medium and high-end applications or in high speed machinery.

NX5000 module, a part of Nexto Series, is used in applications that require more Ethernet Interfaces than already available on Nexto CPUs or in applications where is necessary a high availability of automation system with uses of network redundancy.



Its main features are:

- Simultaneous support to MODBUS TCP and MODBUS RTU over TCP
- Simultaneous operation as MODBUS master/client and server/slave
- Redundant architecture support (half-cluster)
- Network redundancy support (NIC teaming)
- Hot swap support
- Auto crossover Ethernet Interface
- All configuration and parameterization through Master-Tool IEC XE
- One Touch Diag
- Electronic Tag on Display
- LCD and LED for diagnostic indication
- Gratuitous ARP after CPU configuration and as active interface (redundancy)
- Supports up to 128 simultaneous connections
- Protection against flood attacks

## 2. Ordering Information

### 2.1. Included Items

The product package contains the following items:

- NX5000 module
- Installation guide

### 2.2. Product Code

The following code should be used to purchase the product:

Code	Description
NX5000	Ethernet Module

Table 1: Product Code

## 3. Innovative Features

Nexto Series brings to the user many innovations regarding utilization, supervision and system maintenance. These features were developed focusing a new concept in industrial automation.



**One Touch Diag:** One Touch Diag is an exclusive feature that Nexto Series brings to PLCs. With this new concept, the user can check diagnostic information of any module present in the system directly on CPU's graphic display with one single press in the diagnostic switch of the respective module. OTD is a powerful diagnostic tool that can be used offline (without supervisor or programmer), reducing maintenance and commissioning times.

**ETD – Electronic Tag on Display:** Another exclusive feature that Nexto Series brings to PLCs is the Electronic Tag on Display. This new functionality brings the process of checking the tag names of any I/O pin or module used in the system directly to the CPU's graphic display. Along with this information, the user can check the description, as well. This feature is extremely useful during maintenance and troubleshooting procedures.

**DHW – Double Hardware Width:** Nexto Series modules were designed to save space in user cabinets or machines. For this reason, Nexto Series delivers two different module widths: Double Width (two backplane rack slots are required) and Single Width (only one backplane rack slot is required). This concept allows the use of compact I/O modules with a high-density of I/O points along with complex modules, like CPUs, fieldbus masters and power supply modules.



**iF Product Design Award 2012:** Nexto Series was the winner of iF Product Design Award 2012 in industry + skilled trades group. This award is recognized internationally as a seal of quality and excellence, considered the Oscars of the design in Europe..

## 4. Product Features

### 4.1. General Features

	NX5000
Backplane rack occupation	2 sequential slots
HSDN	Yes
Hot swap support	Yes
Status and diagnostic indication	Display, web pages and CPU's internal memory
One Touch Diag (OTD)	Yes
Electronic Tag on Display (ETD)	Yes
Isolation	
NET 1 to logic	1500 Vac / 1 minute
NET 1 to protective earth ⊕	1500 Vac / 1 minute
Logic to protective earth ⊕	1250 Vac / 1 minute
Current consumption from backplane rack power supply	400 mA
Power dissipation	2 W
IP level	IP 20
Operating temperature	0 to 60 °C
Storage temperature	-25 to 75 °C
Operating and storage relative humidity	5% to 96%, non-condensing
Conformal coating	Yes
Module dimensions (W x H x D)	36.00 x 114.63 x 117.07 mm
Package dimensions (W x H x D)	44.00 x 122.00 x 147.00 mm
Weight	250 g
Weight with package	300 g

Table 2: General Features

**Notes:**

**HSDN (High Speed Deterministic Network):** HSDN is the name given to a network where the user can determine the maximum latency for a given data transfer.

**Logic:** Logic is the name for the internal interfaces such as processors, memories and backplane rack interfaces.

**Conformal coating:** Conformal coating protects the electronic components inside the product from moisture, dust and other harsh elements to electronic circuits.

**4.2. Standards and Certifications**



Standards and Certifications	
<b>IEC</b>	61131-2: Industrial-process measurement and control - Programmable controllers - Part 2: Equipment requirements and tests
	DNV Type Approval – DNV-CG-0339 (TAA000013D)
<b>CE</b>	2014/30/EU (EMC) 2014/35/EU (LVD) 2011/65/EU and 2015/863/EU (ROHS)
<b>UK CA</b>	S.I. 2016 No. 1091 (EMC) S.I. 2016 No. 1101 (Safety) S.I. 2012 No. 3032 (ROHS)
	UL/cUL Listed – UL 61010-1 UL 61010-2-201 (file E473496)
<b>EAC</b>	TR 004/2011 (LVD) CU TR 020/2011 (EMC)

Table 3: Standards and Certifications

## 4.3. NET 1

	NX5000
<b>Connector</b>	RJ45 female shielded
<b>Auto Crossover</b>	Yes
<b>Maximum cable size</b>	100 m
<b>Cable type</b>	UTP or ScTP, level 5
<b>Baud rate</b>	10/100 Mbps
<b>Physical layer</b>	10/100BASE-TX
<b>Data link layer</b>	LLC (Logical Link Control)
<b>Network layer</b>	IP (Internet Protocol)
<b>Transport layer</b>	TCP (Transmission Control Protocol)
<b>Application layer</b>	MODBUS TCP client MODBUS TCP server MODBUS RTU over TCP master MODBUS RTU over TCP slave
<b>TCP port configurable range</b>	2 to 65534
<b>Maximum sockets supported value</b>	128
<b>Gratuitous ARP messages</b>	Yes
<b>Diagnostics</b>	LEDs – green (speed), yellow (link/activity)
<b>Isolation</b>	1500 Vac / 1 minute

Table 4: NET 1 Features

**Notes:**

**NET 1:** Ethernet interface cannot be used for programming and debugging Nexto Series CPUs.

**Gratuitous ARP:** NET1 Ethernet interface sends spontaneously ARP type packets in broadcast, informing its IP and MAC address for all devices interconnected to the network. These packets are sent during the download of a new application by the MasterTool IEC XE software and in the startup of a NX5000 interface. 5 ARP commands are sent, with an initial interval of 200 ms, doubling the interval between every new triggered command, totalizing 3 s. Example: First trigger occurs at time 0, the second one at 200 ms, the third one at 600 ms and so forth until the fifth trigger occurs at time 3 s.

## 4.4. Compatibility with Other Products

Nexto Series' CPUs documentation must be consulted to check which CPUs allow the use of NX5000 modules. The table below shows from which software version and product revision the listed modules are compatible with NX5000.

Product revision	Compatible MasterTool IEC XE version
AC or higher	1.20 or higher

Table 5: Compatibility with Other Products

**Note:**

**Product revision:** if the software/firmware is upgraded in the field, the product revision indicated on the label will no longer match the actual revision of the product.

### 4.5. Physical Dimensions

Dimensions in mm.

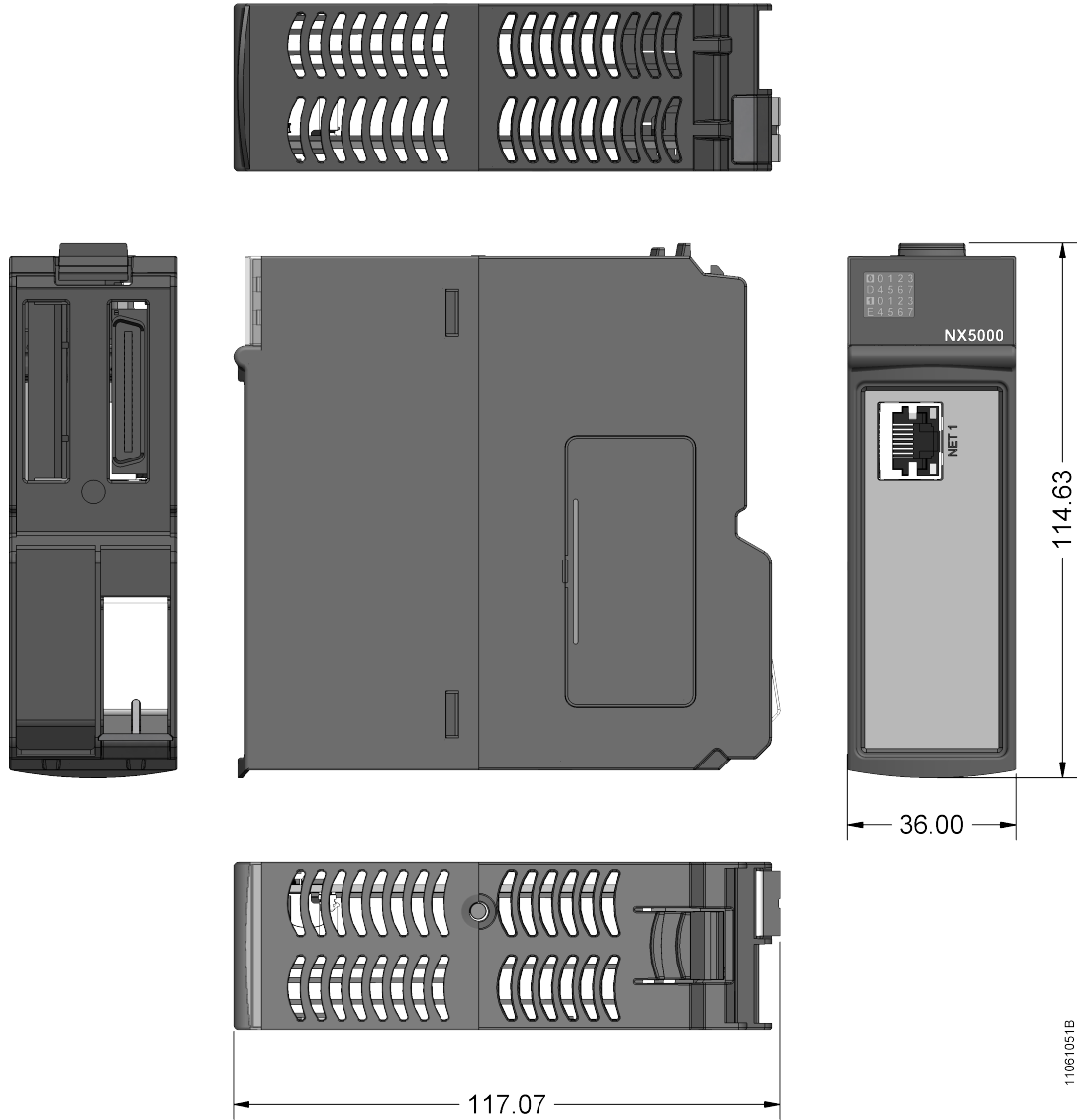

Figure 1: Physical Dimensions

## 5. Installation

### 5.1. Electrical Installation

The following figure shows the electrical installation on the backplane rack.

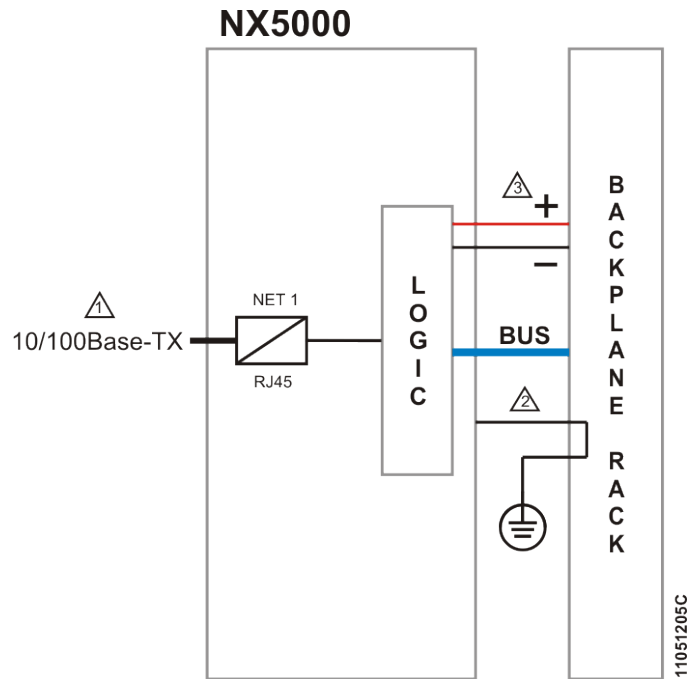

Figure 2: Electric diagram

**Note:**

All information about electrical installation, mechanical assembly and module insertion can be found at Nexto Series User Manual - MU214000.

## 6. Configuration

Nexto Series CPUs User Manual - MU214605 must be consulted for information about module configuration.

### 6.1. Process Data

The process data, when available, are the variables used for access and control the module. The table below shows all the variables delivered by NX5000.

Process data	Description	Type	Update
Reserved	Reserved for internal use	%QB (Read/Write)	Always
Reserved	Reserved for internal use	%QB (Read/Write)	Always
Reserved	Reserved for internal use	%IW (Read)	Always
Reserved	Reserved for internal use	%IW (Read)	Always
Reserved	Reserved for internal use	%IW (Read)	Always

Table 6: Process Data

**Note:**

**Update:** This field indicates if the respective process data is updated by CPU and NX5000. If it is set as Always, it means that the process data is always updated.

### 6.2. Module Parameters

Name	Description	Standard value
%Q Start Address of Module Diagnostics Area	Sets initial address of module Diagnostics.	–

Table 7: Module Parameters

**Note:**

**Standard value:** MasterTool IEC XE programmer fills it automatically, but allows the user to edit its initial offset. The limit depends on the CPU supported model (details at CPUs Nexto Series User Manual – MU214605).

## 7. Maintenance

Altus recommends that all modules' connections be checked and that all dust or any kind of dirt at the module's enclosure be removed at least every 6 months.

NX5000 offers five important features to assist the user during maintenance: Electronic Tag on Display, One Touch Diag, Status and diagnostics indicators, web page with complete status and diagnostics list, and diagnostics mapped to internal memory.

### 7.1. Electronic Tag on Display and One Touch Diag





Electronic Tag on Display and One Touch Diag are important features that provides for the user the option to check the tag, description and diagnostics related to a given module directly on the CPU display.

To check the tag and diagnostics of a given module, it's required only one short press on its diagnostic switch. After pressing once, CPU will start to scroll tag information and diagnostic information of the module. To access the respective description for the module, just long press the diagnostic switch of the respective module.



More information about Electronic Tag on Display and One Touch Diag can be found at Nexto Series CPUs User Manual – MU214605.

## 7.2. Status and Diagnostic Indications

All Nexto I/O modules have a display with the following symbols: D, E,  and  and numerical characters. The states of the symbols D, E,  and  are common for all Nexto Series modules. These states can be consulted in the table below.

The meaning of the numerical characters can be different for specific modules.

### 7.2.1. D and E States

D	E	Description	Causes	Solution	Priority
Off	Off	Display failure or module off	Disconnected module. No Power supply. Hardware failure	Check if the module is completely connected to the backplane rack and if the backplane rack is supplied by an external power supply.	-
On	Off	Normal use	-	-	9 (Lower)
Blinking 1x	Off	Active Diagnostic	There is at least one active diagnostic related to the module NX5000	Check what the active diagnostic is. More information can be found at <a href="#">Status and Diagnostics Mapped to Variables</a> .	8
Blinking 2x	Off	CPU in STOP mode	CPU in STOP mode	Check if CPU is in RUN mode. More information can be found on CPU's documentation.	7
Blinking 3x	Off	Reserved	-	-	6
Blinking 4x	Off	Non fatal fault	Failure in some hardware or software component, which does not have impact on the basic functionality of the product	Check the module diagnostic information. If it is a hardware fault, provide the replacement of this part. If it is a software fault, please contact the Technical Support.	5
Off	Blinking 1x	Parameter error	The module is not parameterized or has not received the new parameterization	Check if the module parameters are correct.	4
Off	Blinking 2x	Loss of master	Loss of communication between module and CPU	Check if the module is completely connected to the backplane rack. Check if CPU is in RUN mode.	3
Off	Blinking 3x	Reserved	-	-	2
Off	Blinking 4x	Fatal hardware error	Hardware error	Contact Altus' support team in case of fatal hardware error.	1 (Higher)

Table 8: D and E States

## 7.2.2. 0, 1 and Numeral Characters

The segments 0 and 1 should be normally off. These two segments will start to blink when the module is on the Diagnostic Mode (Electronic Tag on Display and One Touch Diag).

The NX5000 module uses two numerical characters only when configured with communication redundancy, in this case, the character 0 indicates that the module is in standby and the character 1 indicates that the module is active. When the NX5000 module is used without communication redundancy, numerical characters are not used.

## 7.3. RJ45 Connector LEDs

Both LEDs placed in the RJ45 connector, identified by NET 1, help the user in the installed physical network problem detection, indicating the network LINK speed and the existence of interface communication traffic. The LEDs description is presented in the table below.

Yellow	Green	Description
Off	Off	Network LINK absent.
On	Off	10 Mbits/s network LINK.
On	On	100 Mbits/s network LINK.
Blinking	–	Occurrence of Ethernet network transmission or reception, for or to this IP address. It blinks when there's module demand, not on every transmission or reception, i.e. blinking frequency doesn't correspond to data transmission or reception frequency.

Table 9: RJ45 Connector LEDs

## 7.4. Web Page with Complete Status and Diagnostic List

Another way to access diagnostic information on Nexto Series is via web pages. Nexto Series CPUs have an embedded web pages server that provides all Nexto status and diagnostic information, which can be accessed using a simple browser.

More information about web page with complete status and diagnostic list can be found at Nexto Series User Manual – MU214600.

## 7.5. Status and Diagnostics Mapped to Variables

All diagnostics of the NX5000 module can be accessed through variables that can be manipulated by the user application or even sent to a supervisory using a communication channel. There are two different ways to access diagnostics in the user application: use of the AT directive on symbolic variables or variables of direct representation. Altus recommends the use of symbolic variables. The table below shows all the diagnostics available for the NX5000 module and their respective memory addresses, description, symbolic variable and text that will be shown on the graphic display of the CPU and on the web.

## 7.5.1. General Diagnostics

Direct Representation Variable Variable	Bit	Diagnostic Message	Symbolic Variable DG_NX5000.*	Description
%QB(n)	0..7	Reserved		
%QB(n+1)	0	MODULE W/ DIAGNOSTICS	tGeneral.bActiveDiagnostics	TRUE – Module has active diagnostics
		-		FALSE – Module doesn't have active diagnostic
	1	MODULE W/ FATAL ERROR	tGeneral.bFatalError	TRUE – Fatal error
		-		FALSE – No fatal error
	2	CONFIG. MISMATCH	tGeneral.bConfigMismatch	TRUE – Parameter error
		-		FALSE – Parameters ok
	3	WATCHDOG ERROR	tGeneral.bWatchdogError	TRUE – Watchdog has been detected
		-		FALSE – No watchdog
	4	OTD SWITCH ERROR	tGeneral.bOTDSwitchError	TRUE – Failure on the diagnostic switch
		-		FALSE – No failure on the diagnostic switch
	5..7	Reserved		
	%QB(n+2)	0	NET 1 LINK DOWN	NX5000.bStsEthLink
-			FALSE – NET 1 interface connected	
1		-	NX5000.bNX5000NoCfg	TRUE – Internal failure on NET 1 interface
		-		FALSE – No internal failure on NET 1 interface
2..7	Reserved			
%QB(n+3)	0..7	-	NX5000.bStsEthSpd	0 - NET 1 Link down 1 - NET 1 10 Mbps 2 - NET 1 100 Mbps

Table 10: General Diagnostics

**Notes:**

**Direct Representation Variable:** “n” is the address defined in the field %Q Start Address of Module Diagnostics Area on the NX5000's configuration screen – Module Parameters tab in the MasterTool IEC XE.

**Symbolic Variable:** Some symbolic variables serve to accessing diagnostics. This diagnostics are stored into the addressing memory, then the AT directive is used to map the symbolic variables in the addressing memory. The AT directive is a reserved word in the MasterTool IEC XE that uses this directive to declare the diagnostics automatically on symbolic variables. All symbolic variables declared automatically can be found inside of diagnostics object.

## 7.5.2. Detailed Diagnostics

The list below indicates additional information related to NX5000's status and diagnostics that can be found on variables.

Direct Representation Variable	Size	AT Variable DG_NX5000.tStsEthernet.*	Description
%QB(n+4)	BYTE	byIPStringSize	Size of szIPAddress
%QB(n+5)	STRING(16)	szIPAddress	NET 1 IP address
%QB(n+21)	BYTE	byMaskStringSize	Size of szSubnetworkMask
%QB(n+22)	STRING(16)	szSubnetworkMask	NET 1 subnetwork mask
%QB(n+38)	BYTE	byGatewayStringSize	Size of szGatewayAddress
%QB(n+39)	STRING(16)	szGatewayAddress	NET 1 gateway
%QB(n+55)	BYTE	byMACStringSize	Size of szMACAddress
%QB(n+56)	STRING(18)	szMACAddress	NET 1 MAC address
%QW(n+74)	WORD	-	Reserved
%QD(n+76)	DWORD	dwPacketsSent	Total packets sent
%QD(n+80)	DWORD	dwPacketsReceived	Total packets received
%QD(n+84)	DWORD	dwBytesSent	Total bytes sent
%QD(n+88)	DWORD	dwBytesReceived	Total bytes received
%QW(n+92)	WORD	wTXErrors	Transmission errors
%QW(n+94)	WORD	wTXDropErrors	Transmission drop errors
%QW(n+96)	WORD	wTXCollisionErrors	Transmission collision errors
%QW(n+98)	WORD	wRXErrors	Receiving errors
%QW(n+100)	WORD	wRXDropErrors	Receiving drop errors
%QW(n+102)	WORD	wRXFrameErrors	Receiving frame errors

Table 11: Detailed Diagnostics

## 8. Manuals

For correct application, MODBUS configuration and utilization Nexto Series CPUs User Manual - MU214605 must be consulted.

For further technical details, configuration, installation and programming of Nexto Series, the table below should be consulted.

The table below is only a guide of some relevant documents that can be useful during the use, maintenance, and programming of NX5000. The complete and updated table containing all documents of Nexto Series can be found at Nexto Series User Manual – MU214600.

<b>Document code</b>	<b>Description</b>	<b>Language</b>
<b>CE114000</b>	Nexto Series – Technical Characteristics	English
<b>CT114000</b>	Série Nexto – Características Técnicas	Portuguese
<b>CS114000</b>	Serie Nexto – Características Técnicas	Spanish
<b>MU214600</b>	Nexto Series User Manual	English
<b>MU214000</b>	Manual de Utilização Série Nexto	Portuguese
<b>MU214605</b>	Nexto Series CPUs User Manual	English
<b>MU214100</b>	Manual de Utilização UCPs Série Nexto	Portuguese
<b>MU299609</b>	MasterTool IEC XE User Manual	English
<b>MU299048</b>	Manual de Utilização MasterTool IEC XE	Portuguese

Table 12: Related documents