

1. Product Description

Nexto Series is a powerful and complete Programmable Logic Controller (PLC) Series with unique and innovative features. Due to its flexibility, smart design, enhanced diagnostics capabilities and modular architecture, Nexto PLC can be used for control systems in medium and high-end applications or in high speed machinery.

NX4010 redundancy link module, a part of Nexto Series, is used to redundancy applications with half-clusters, where is necessary a high availability of automation system. The NX4010 is responsible for connecting the two half-clusters and providing the synchronism between them in such way that the stand-by half-cluster keeps all internal variables, input values and output values updated according to the active half-cluster. The interface between two redundant half-clusters is also redundant, where is formed by two cables of synchronism.

Besides providing an interface between two redundant half-clusters, the module NX4010 also has an interface to the Redundancy Control Panel, PX2612 that is used to control and to verify the redundant system states.



Its main features are:

- Allows full synchronization between two half-clusters
- Redundant channels of synchronism between the half-clusters
- Automatically switchover (change of active half-cluster) in case of time-out communication between NX4010 and its respective CPU
- Ability to shut down the opposite half-cluster
- One Touch Diag
- Electronic Tag on Display
- LCD and LED for diagnostic indication

2. Ordering Information

2.1. Included Items

The product package contains the following items:

- NX4010 module

2.2. Product Code

The following code should be used to purchase the product:

Code	Description
NX4010	Redundancy Link Module

Table 1: Product Code

2.3. Related Products

The following products must be purchased separately when necessary:

Code	Description
PX2612	Redundancy Control Panel
AL-2317/A	CMDB9-CFDB9 Cable
AL-2317/B	CMDB9-CFDB9 Cable
AL-2319	RJ45-RJ45 Cable

Table 2: Related Products

Notes:

PX2612: PX2612 is a control panel used to control and to verify the redundant system states.

AL-2317/A, AL-2317/B: the cables AL-2317/A and AL-2317/B are used to connect the CONTROL interfaces of the both NX4010 at the PX2612 control panel.

AL-2319: the cable AL-2319 is used to connect NET 1 and NET 2 interfaces of the NX4010 of the two redundant half-clusters.

3. Innovative Features

Nexto Series brings to the user many innovations regarding utilization, supervision and system maintenance. These features were developed focusing a new concept in industrial automation.



One Touch Diag: One Touch Diag is an exclusive feature that Nexto Series brings to PLCs. With this new concept, the user can check diagnostic information of any module present in the system directly on CPU's graphic display with one single press in the diagnostic switch of the respective module. OTD is a powerful diagnostic tool that can be used offline (without supervisor or programmer), reducing maintenance and commissioning times.

ETD – Electronic Tag on Display: Another exclusive feature that Nexto Series brings to PLCs is the Electronic Tag on Display. This new functionality brings the process of checking the tag names of any I/O pin or module used in the system directly to the CPU's graphic display. Along with this information, the user can check the description, as well. This feature is extremely useful during maintenance and troubleshooting procedures.

DHW – Double Hardware Width: Nexto Series modules were designed to save space in user cabinets or machines. For this reason, Nexto Series delivers two different module widths: Double Width (two backplane rack slots are required) and Single Width (only one backplane rack slot is required). This concept allows the use of compact I/O modules with a high-density of I/O points along with complex modules, like CPUs, fieldbus masters and power supply modules.



iF Product Design Award 2012: Nexto Series was the winner of iF Product Design Award 2012 in industry + skilled trades group. This award is recognized internationally as a seal of quality and excellence, considered the Oscars of the design in Europe..

4. Product Features

4.1. General Features



	NX4010
Backplane rack occupation	2 sequential slots
Hot swap support	Yes
Status and diagnostic indication	Display, web pages and CPU's internal memory
One Touch Diag (OTD)	Yes
Electronic Tag on Display (ETD)	Yes
Isolação	
NET 1 to logic	1500 Vac / 1 minute
NET 1 to protective earth 	1500 Vac / 1 minute
NET 1 to NET 2	1500 Vac / 1 minute
NET 2 to logic	1500 Vac / 1 minute
NET 2 to protective earth 	1500 Vac / 1 minute
Logic to protective earth 	1500 Vac / 1 minute
Current consumption from backplane rack power supply	500 mA
Power dissipation	2.5 W
IP level	IP 20
Operating temperature	0 to 60 °C
Storage temperature	-25 to 75 °C
Relative humidity for operation and storage	5% to 96%, non condensing
Conformal coating	Yes
Module dimensions (W x H x D)	36.00 x 114.63 x 115.30 mm
Package dimensions (W x H x D)	44.00 x 122.00 x 147.00 mm
Net weight	250 g
Gross weight	300 g

Table 3: General Features

Notes:

Status and diagnostic indication: More information about diagnostic and status indication can be found on the topic [Maintenance](#).

Logic: Logic is the name for the internal interfaces such as processors, memories and backplane rack interfaces.

Isolation: The CONTROL interface is located in the isolation group of Logic. It means that there isn't isolation between Logic and CONTROL.

Conformal coating: Conformal coating protects the electronic components inside the product from moisture, dust and other harsh elements to electronic circuits.

4.2. Standards and Certifications



Standards and Certifications	
IEC	61131-2: Industrial-process measurement and control - Programmable controllers - Part 2: Equipment requirements and tests
	DNV Type Approval – DNV-CG-0339 (TAA000013D)
CE	2014/30/EU (EMC) 2014/35/EU (LVD) 2011/65/EU and 2015/863/EU (ROHS)
UK CA	S.I. 2016 No. 1091 (EMC) S.I. 2016 No. 1101 (Safety) S.I. 2012 No. 3032 (ROHS)
	UL/cUL Listed – UL 61010-1 UL 61010-2-201 (file E473496)
EAC	TR 004/2011 (LVD) CU TR 020/2011 (EMC)

Table 4: Standards and Certifications

4.3. NET 1 and NET 2

NET 1 and NET 2 are the external interfaces, called Redundancy Links. The Redundancy Links connect two NX4010, placed in different half-clusters and allow redundant data exchange between them. NET 1 and NET 2 form a redundant interface, it means that the system works properly with only one Redundancy Link, NET 1 or NET 2. In case of loss of link in one redundancy interface, the system will keep working and will indicate a diagnostic informing the loss of link.

NET 1 interface must be connected to another NET 1 interface, while NET 2 interface must be connected to another NET 2 interface.

4.4. CONTROL

CONTROL is the interface between NX4010 and the Redundancy Control Panel PX2612. This interface is used for three reasons:

- Control PX2612's LEDs used to show the status of each half-cluster
- Read PX2612's buttons to check if the user is requesting a manual operation
- Control the power supply of the opposite half-cluster

Controlling the power supply of the opposite half-cluster is a very important point, because there are some extreme conditions, like loss of two Redundancy Links, where the only way to ensure that there is only one master for all remote I/Os is switching the opposite half-cluster off.

4.5. System Configurations

Suggested configurations using NX4010 are shown below:

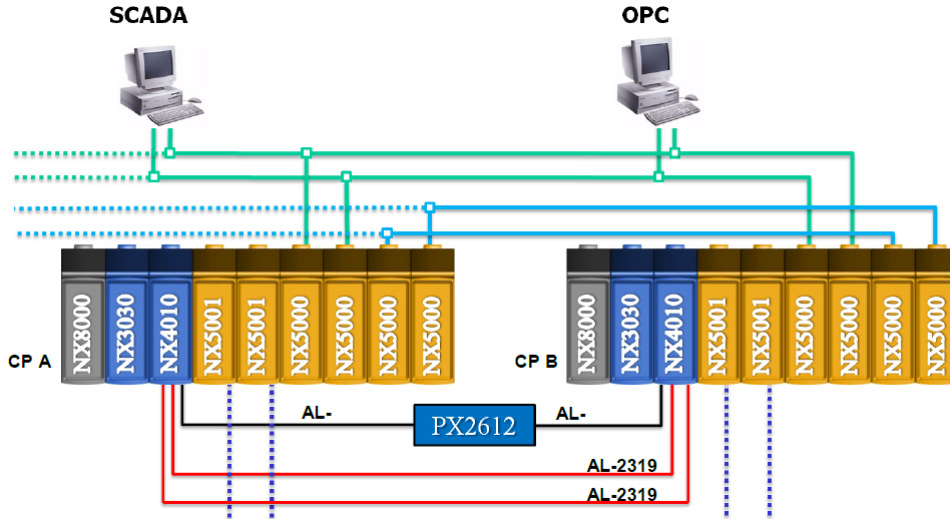

Figure 1: System Configurations

4.6. Software Features

Nexto Series brings to the user the MasterTool IEC XE, a powerful tool that provides a complete interface used to program all Nexto Series' Modules. This means that there is no additional software to make the redundancy parameterization, all settings are done in the same software used to program Nexto CPUs.

4.7. Compatibility with Other Products

The NX4010 module was developed to be used in Nexto Series half-clusters redundancy solution. Nexto Series' CPUs documentation must be consulted to check which CPUs allows its use. The table below shows from which software version and product revision the listed modules are compatible with NX4010.

Product revision	MasterTool IEC XE version	NX3030 Firmware version
AC or higher	1.20 or higher	1.1.0.0 or higher

Table 5: Compatibility with Other Products

Note:

Product revision: If the software/firmware is upgraded in the field, the product revision indicated on the label will no longer match the actual revision of the product.

4.8. Physical Dimensions

Dimensions in mm.

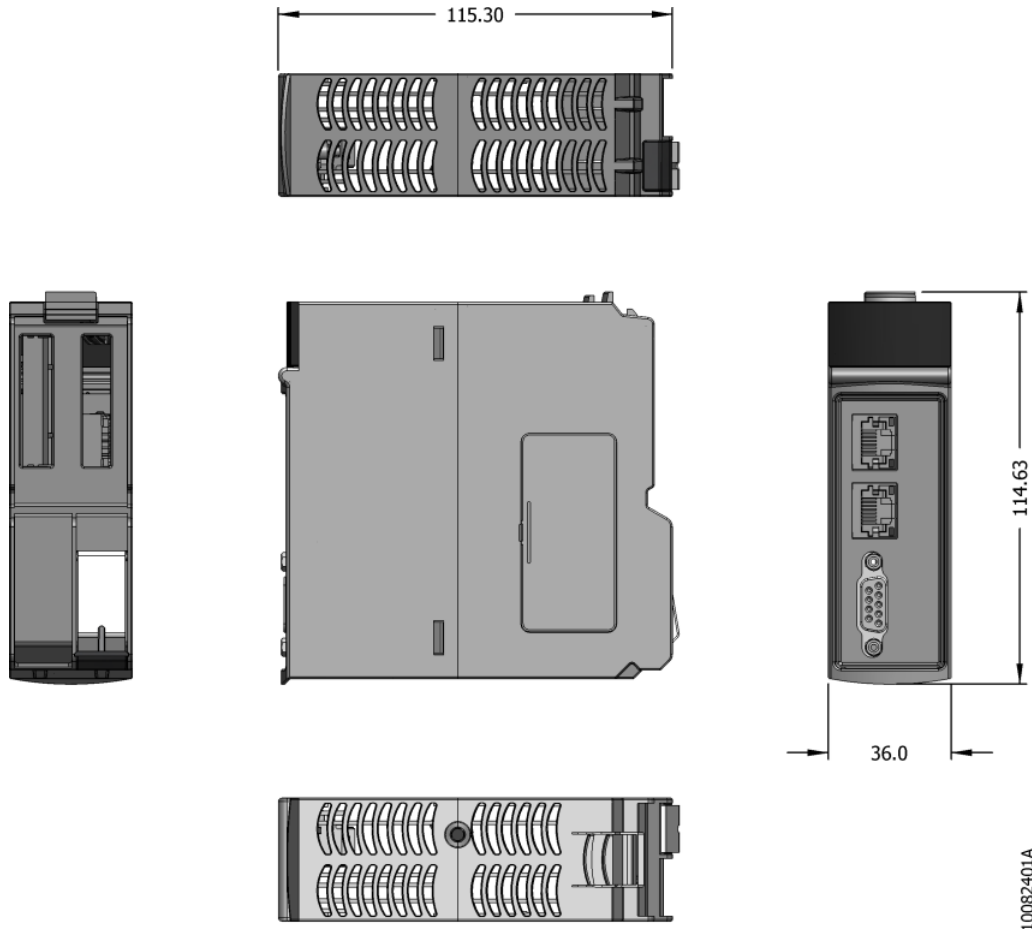

10082-01A

Figure 2: Physical Dimensions

5. Installation

For the correct installation of this product, it is necessary to use a rack (backplane rack) and it must be carried out according to the mechanical and electrical installation instructions that follow.

5.1. Product Identification

This product has some parts that must be observed before installation and use. The following figure identifies each of these parts.

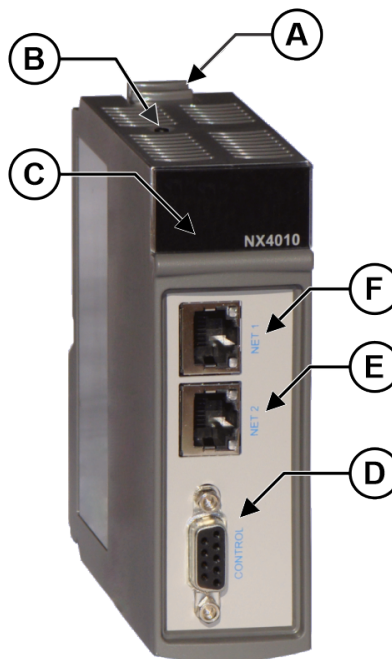

Figure 3: NX4010

- Ⓐ Fixing lock.
- Ⓑ Diagnostic switch.
- Ⓒ Status and diagnostic display.
- Ⓓ Female DB9 connector for redundancy control.
- Ⓔ RJ45 connector for redundancy link.
- Ⓕ RJ45 connector for redundancy link.

The product has in its mechanics a label that identifies it and in it are presented some symbols whose meaning is described below:



Attention! Before using the equipment and installing, read the documentation.



Direct Current.

5.2. Electrical Installation

The electrical installation on the backplane rack can be seen in the figure below.

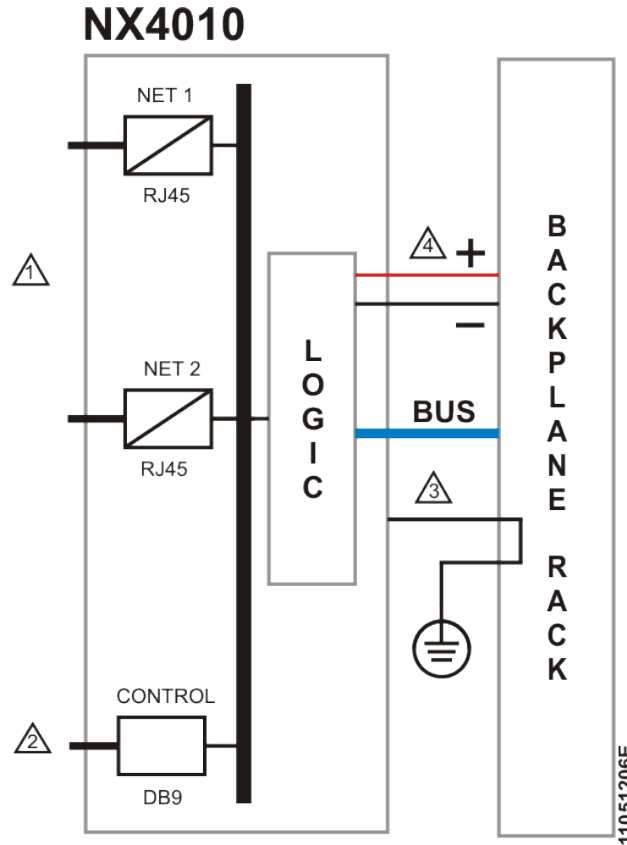

Figure 4: Electrical Installation

Diagram Notes:

- ① Redundancy link.
- ② Redundancy interface control.
- ③ The module is grounded through the Nexto Series backplane racks.
- ④ The module power supply is derived from the connection to the backplane rack, not requiring external connections.
- ⊕ Protective conductor terminal.

All indication about half-cluster redundancy installation can be found at Nexto Series User Manual - MU214600.

5.3. Mechanical Assembly

The mechanical mounting of this module is described at Nexto Series User Manual - MU214600. There is no particular issue on the installation of this module.

ATTENTION

Products with broken warranty seal are not covered in warranty.

CAUTION



The device is sensitive to static electricity (ESD). Always touch in a metallic grounded object before handling it.

DANGER



Nexto Series can operate with voltage up to 250 Vac. Special care must be taken during the installation, which should only be done by qualified technical personnel. Do not touch on the wiring field when in operation.

6. Configuration

All indication about half-cluster redundancy configuration can be found at Nexto Series User Manual - MU214600.

6.1. Process Data

The process data, when available, are the variables used to access and control the module. The table below shows all the variables used by NX4010.

Process data	Description	Type	Update
Reserved	Reserved for internal use	%QB (Read/Write)	Always
Reserved	Reserved for internal use	%IB (Read)	Always
Reserved	Reserved for internal use	%IB (Read)	Always
Reserved	Reserved for internal use	%IW (Read)	Always

Table 6: Process Data

Note:

Update: The *Update* field indicates if the respective process data is updated by CPU and NX4010. If it is set as *Always*, it means that the process data is always updated.

6.2. Module Parameters

Name	Description	Standard value
%Q Start Address of Module Diagnostics Area	Defines the start address of the module diagnostics.	-

Table 7: Module Parameters

Note:

Standard value: MasterTool IEC XE programmer fills it automatically, but allows the user to edit its initial offset. The limit depends on the CPU supported model (details at Nexto Series User Manual - MU214600).

7. Maintenance

Altus recommends that all modules' connections be checked and that all dust or any kind of dirt at the module's enclosure be removed at least every 6 months.

NX4010 offers five important features to assist the user during maintenance: Electronic Tag on Display, One Touch Diag, Status and diagnostics indicators, web page with complete status and diagnostics list, and diagnostics mapped to internal memory.





7.1. Electronic Tag on Display and One Touch Diag

Electronic Tag on Display and One Touch Diag are important features that provides for the user the option to check the tag, description and diagnostics related to a given module directly on the CPU's display.

To check the tag and diagnostics of a given module, it's required only one short press on its diagnostic switch. After pressing once, CPU will start to scroll tag information and diagnostic information of the module. To access the respective description for the module, just long press the diagnostic switch of the respective module.

More information about Electronic Tag on Display and One Touch Diag can be found at Nexto Series User Manual - MU214600.

7.2. Status and Diagnostics Indications

All Nexto I/O modules have a display with the following symbols: D, E,  and  and numerical characters. The states of the symbols D, E,  and  are common for all Nexto Series modules. These states can be consulted in the table below.



The meaning of the numerical characters can be different for specific modules. NX4010 doesn't use these segments.

7.2.1. D and E States

D	E	Description	Cause	Solution	Priority
Off	Off	Display failure or module off	Module off, external power supply failure or hardware failure	Check if the module is completely connected to the backplane rack and if the backplane rack is supplied by an external power supply.	-
On	Off	Normal use	-	-	9 (Lower)
Blinking 1x	Off	Active Diagnostics	There is at least one active diagnostic related to the module	Check what the active diagnostic is. More information can be found at Diagnostics Mapped through Variables section of this document.	8
Blinking 2x	Off	CPU in STOP mode	CPU in STOP mode	Check if CPU is in RUN mode. More information can be found on CPU's documentation.	7
Blinking 3x	Off	Reserved	-	-	6
Blinking 4x	Off	Non-fatal fault	Failure in some hardware or software component, which does not have impact on the basic functionality of the product	Check the module diagnostic information. If it is a hardware fault, provide the replacement of this part. If it is a software fault, please contact the Technical Support.	5
Off	Blinking 1x	Parameterization error	The module isn't parameterized or didn't receive the new parameterization	Check if the module parameterization is ok.	4
Off	Blinking 2x	Loss of master	Loss of communication between module and CPU	Check if the module is completely connected to the backplane rack. Check if CPU is in RUN mode.	3
Off	Blinking 3x	Reserved	-	-	2
Off	Blinking 4x	Fatal hardware fault	Hardware fault	In this case, the module should return to the manufacturer.	1 (Higher)

Table 8: D and E States

7.2.2. 0, 1 and Numerical Characters

The segments  and  should be normally off. These two segments will start to blink when the module is on the Diagnostic Mode (Electronic Tag on Display and One Touch Diag).

The Numerical Characters aren't used in this module.

7.3. RJ45 Connector LEDs

Both LEDs placed in the RJ45 connectors, identified by NET 1 and NET 2, help the user in the installed physical network problem detection, indicating the network LINK speed and the existence of interface communication traffic. The LEDs description is presented in the table below.

Yellow	Green	Description
Off	Off	Network LINK absent.
On	Off	10 Mbits/s network LINK.
On	On	100 Mbits/s network LINK.
Blinking	-	Occurrence of transmission or reception. It blinks when there is module demand and not every transmission or reception, i.e. blinking frequency doesn't correspond to data transmission or reception frequency.

Table 9: RJ45 Connector LEDs

7.4. Web Page with Complete Status and Diagnostic List

Another way to access diagnostic information on Nexto Series is via web pages. Nexto Series CPUs have an embedded web pages server that provides all Nexto status and diagnostic information, which can be accessed using a simple browser.

More information about web page with complete status and diagnostic list can be found in the specific manual for each CPU model listed in the table 11.

7.5. Diagnostics Mapped through Variables

All NX4010's diagnostics can be accessed through variables that can be handled by the user application or even forwarded to a supervisory system using a communication channel. There are two different ways to access diagnostics in the user application: using symbolic variables with AT directive or addressing memory. Altus recommends use symbolic variables for diagnostic accessing. The table below shows all available diagnostics for NX4010 and their respective memory address, description, symbolic variable and string that will be shown on the CPU's graphical display and web.

Addressing Memory		Diagnostic Message	Symbolic Variable DG_NX4010.tGeneral.*	Description
Variable	Bit			
%QB(n)	0..7	Reserved		
%QB(n+1)	0	MODULE W/ DIAGNOSTICS	bActiveDiagnostics	TRUE – Module has active diagnostics
		NO DIAG		FALSE – Module doesn't have active diagnostic
	1	MODULE W/ FATAL ERROR	bFatalError	TRUE – Fatal error
		-		FALSE – No fatal error
	2	CONFIG. MISMATCH	bConfigMismatch	TRUE – Parameterization error
		-		FALSE – Parameterization ok
	3	WATCHDOG ERROR	bWatchdogError	TRUE – Watchdog has been detected
		-		FALSE – No watchdog
	4	OTD SWITCH ERROR	bOTDSwitchError	TRUE – Failure on the diagnostic switch

Addressing Memory Variable		Diagnostic Message	Symbolic Variable DG_NX4010.tGeneral.*	Description
	5..7	-		FALSE – No failure on the diagnostic switch
				Reserved
%QB(n+2)	0..7			Reserved
%QB(n+3)	0	NET1 LINK DOWN	bNET1LinkDown	TRUE – NET 1 interface isn't properly connected
		-		FALSE – NET 1 interface is connected
	1	NET2 LINK DOWN	bNET2LinkDown	TRUE – NET 2 interface isn't properly connected
		-		FALSE – NET 2 interface is connected
	2..7			Reserved

Table 10: Diagnostics

Notes:

Addressing Memory: “n” is the address defined in the field %Q Start Address of Module Diagnostics Area on the NX4010’s configuration screen – Module Parameters tab in the MasterTool IEC XE.

Symbolic Variable: Some symbolic variables serve to accessing diagnostics. This diagnostics are stored into the addressing memory, then the AT directive is used to map the symbolic variables in the addressing memory. The AT directive is a reserved word in the MasterTool IEC XE that uses this directive to declare the diagnostics automatically on symbolic variables. All symbolic variables declared automatically can be found inside of diagnostics object.

8. Manuals

The table below is only a guide of some relevant documents that can be useful during the use, maintenance, and programming of NX4010. The complete and updated table containing all documents of Nexto Series can be found at Nexto Series User Manual - MU214600.

Código	Descrição	Idioma
CE114000	Nexto Series – Technical Characteristics	English
CT114000	Série Nexto – Características Técnicas	Portuguese
CS114000	Serie Nexto – Características Técnicas	Spanish
MU214600	Nexto Series User Manual	English
MU214000	Manual de Utilização Série Nexto	Portuguese
MU214615	NX3030 CPU User Manual	English
MU214103	Manual de Utilização UCP NX3030	Portuguese
MU299609	MasterTool IEC XE User Manual	English
MU299048	Manual de Utilização MasterTool IEC XE	Portuguese
MP399609	MasterTool IEC XE Programming Manual	English
MP399048	Manual de Programação MasterTool IEC XE	Portuguese

Table 11: Related Documents