

1. Product Description

Nexto Series programmable controllers are the ultimate solution for industrial automation and system control. With high technology embedded, the products of the family are able to control, in a distributed and redundant way, complex industrial systems, machines, high performance production lines and the most advanced processes of Industry 4.0. Modern and high-speed, the Nexto series uses cutting-edge technology to provide reliability and connectivity, helping to increase the productivity of different businesses.

Compact, robust and with high availability, the series products have excellent processing performance and rack expansion possibilities. Its architecture allows easy integration with supervision, control and field networks, in addition to PLC redundancy. The series equipment also offers advanced diagnostics and hot swapping, minimizing or eliminating maintenance downtime and ensuring a continuous production process.



Its main features are:

- 96 Kbytes of dots %I and 96 Kbytes of dots %Q
- Large memory capacity for user application and user data
- 112 Kbytes of retentive or persistent memory
- 32-bit high-speed processing
- Floating point unit
- 2 serial port
- 2 front panel Ethernet interface
- miniSD Card Interface
- Advanced Diagnostic Services
- System Message Log
- Event-driven data reporting
- OPC DA/UA, IEC 60870-5-104, PROFINET, EtherCAT, SNMP and EtherNet/IP protocols
- Clock Synchronism via SNTP or via IEC 60870-5-104
- Web Server Resources
- Redundancy mode for high availability applications
- One Touch Diag
- Compliance with international standard IEC 61131-3
- Real Time Clock (RTC)
- Compact and modern design
- Free of moving parts (fans, active coolers, etc.)

2. Purchase Data

2.1. Included Items

The product package contains the following items:

- NX3030 module

2.2. Product Code

The following code should be used to purchase the product:

Code	Description
NX3030	High-speed CPU, 2 Ethernet ports, 2 serial channels, memory card interface, remote rack expansion and redundancy support

Table 1: Product Code

3. Related products

The following products must be purchased separately when necessary:

Code	Description
MT8500	MasterTool IEC XE
AL-2600	RS-485 network branch and terminator
AL-2306	RS-485 cable for MODBUS or CAN network
AL-2319	RJ45-RJ45 Cable
AL-1729	RJ45-CMDB9 Cable
AL-1748	CMDB9-CFDB9 Cable
AL-1752	CMDB9-CMDB9 Cable
AL-1753	CMDB9-CMDB25 Cable
AL-1754	CMDB9-CFDB9 Cable
AL-1761	CMDB9-CMDB9 Cable
AL-1762	CMDB9-CMDB9 Cable
AL-1763	CMDB9-Terminal Block Cable
AL-1766	CFDB9-Terminal Block Cable
NX9101	32 GB microSD memory card with miniSD and SD adapters
NX9202	RJ45-RJ45 2 m Cable
NX9205	RJ45-RJ45 5 m Cable
NX9210	RJ45-RJ45 10 m Cable
NX9000	8-Slot Backplane Rack
NX9001	12-Slot Backplane Rack
NX9002	16-Slot Backplane Rack
NX9003	24-Slot Backplane Rack
NX8000	30 W 24 Vdc Power Supply Module

Table 2: Related Products

Notes:

MT8500: MasterTool IEC XE is available in four different versions: LITE, BASIC, PROFESSIONAL and ADVANCED. For more details, please check MasterTool IEC XE User Manual - MU299609.

AL-2600: This module is used for branch and termination of RS-422/485 networks. For each network node, an AL-2600 is required. The AL-2600 that is at the ends of network must be configured with termination, except when there is a device with active internal termination, the rest must be configured without termination.

AL-2306: Two shielded twisted pairs cable without connectors, used for networks based on RS-485 or CAN.

AL-2319: Two RJ45 connectors for programming the CPUs of the Nexto Series and Ethernet point-to-point with another device with Ethernet interface communication.

AL-1729: RS-232C standard cable with one RJ45 connector and one DB9 male connector for communication between CPUs of the Nexto Series and other Altus products of the DUO Series, Piccolo Series and Ponto Series.

AL-1748: RS-232C standard cable with one DB9 male connector and one DB9 female connector for communication between CPUs of the Nexto Series and Altus products of the Cimrex Series.

AL-1752: RS-232C standard cable with two DB9 male connectors for communication between CPUs of the Nexto Series and Altus products of the H Series and iX series.

AL-1753: RS-232C standard cable with one DB9 male connector and one DB25 male connector for communication between CPUs of the Nexto Series and Altus products of the H Series.

AL-1754: RS-232C standard cable with one DB9 male connector and one DB9 female connector for communication between CPUs of the Nexto Series and Altus products of the Exter Series or Serial port, RS-232C standard, of a microcomputer.

AL-1761: RS-232C standard cable with two DB9 male connectors for communication between Nexto Series CPUs and Altus products of the AL Series.

AL-1762: RS-232C standard cable with two DB9 male connectors for communication between Nexto Series CPUs.

AL-1763: Cable with one DB9 male connector and terminal block for communication between CPUs of the Nexto Series and products with RS-485/RS-422 standard terminal block.

AL-1766: Cable with a female DB9 connector and terminals for communication between HMI P2 and Nexto Xpress/NX3003 controllers.

NX9202/NX9205/NX9210: Cables used for Ethernet communication and to interconnect the bus expansion modules.

4. Innovative Features

Nexto Series brings to the user many innovations regarding utilization, supervision and system maintenance. These features were developed focusing a new concept in industrial automation.



Battery Free Operation: Nexto Series does not require any kind of battery for memory maintenance and real time clock operation. This feature is extremely important because it reduces the system maintenance needs and allows the use in remote locations where maintenance can be difficult to be performed. Besides, this feature is environmentally friendly.



Easy Plug System: Nexto Series has an exclusive method to plug and unplug I/O terminal blocks. The terminal blocks can be easily removed with a single movement and with no special tools. In order to plug the terminal block back to the module, the frontal cover assists the installation procedure, fitting the terminal block to the module.



Multiple Block Storage: Several kinds of memories are available to the user in Nexto Series CPUs, offering the best option for any user needs. These memories are divided in volatile memories and non-volatile memories. For volatile memories, Nexto Series CPUs offer addressable input (%I), addressable output (%Q), addressable memory (%M), data memory and redundant data memory. For applications that require non-volatile functionality, Nexto Series CPUs bring retain addressable memory (%Q), retain data memory, persistent addressable memory (%Q), persistent data memory, program memory, source code memory, CPU file system (doc, PDF, data) and memory card interface.



One Touch Diag: One Touch Diag is an exclusive feature that Nexto Series brings to PLCs. With this new concept, the user can check diagnostic information of any module present in the system directly on CPU's graphic display with one single press in the diagnostic switch of the respective module. OTD is a powerful diagnostic tool that can be used offline (without supervisor or programmer), reducing maintenance and commissioning times.

OFD – On Board Full Documentation: Nexto Series CPUs are capable of storing the complete project documentation in its own memory. This feature can be very convenient for backup purposes and maintenance, since the complete information is stored in a single and reliable place.

ETD – Electronic Tag on Display: Another exclusive feature that Nexto Series brings to PLCs is the Electronic Tag on Display. This new functionality brings the process of checking the tag names of any I/O pin or module used in the system directly to the CPU's graphic display. Along with this information, the user can check the description, as well. This feature is extremely useful during maintenance and troubleshooting procedures.

DHW – Double Hardware Width: Nexto Series modules were designed to save space in user cabinets or machines. For this reason, Nexto Series delivers two different module widths: Double Width (two backplane rack slots are required) and Single Width (only one backplane rack slot is required). This concept allows the use of compact I/O modules with a high-density of I/O points along with complex modules, like CPUs, fieldbus masters and power supply modules.

High-speed CPU: All Nexto Series CPUs were designed to provide an outstanding performance to the user, allowing the coverage of a large range of applications requirements.



iF Product Design Award 2012: Nexto Series was the winner of iF Product Design Award 2012 in industry + skilled trades group. This award is recognized internationally as a seal of quality and excellence, considered the Oscars of the design in Europe..

5. Product characteristics

5.1. General features

	NX3030
Backplane rack occupation	2 sequential slots
Power supply integrated	No
Ethernet TCP/IP local interface	2
Serial Interface	2
CAN Interface	No
USB Port Host	No
Memory Card Interface	Yes
Real time clock (RTC)	Yes Resolution of 1 ms and maximum variance of 2 s per day.
Watchdog	Yes
Status and diagnostic Indication	Graphic display LEDs System Web Page CPU internal memory
Programming languages	Structured Text (ST) Ladder Diagram (LD) Sequential Function Chart (SFC) Function Block Diagram (FBD) Continuous Function Chart (CFC)
Tasks	Cyclic (periodic) Event (software interruption) External (hardware interruption) Freewheeling (continuous) Status (software interruption)
Online changes	Yes
Maximum number of tasks	32
Maximum number of expansion bus	24
Bus expansion redundancy support	Yes
Maximum number of I/O modules on the bus	128
Maximum number of additional Ethernet TCP/IP interface modules	6
Ethernet TCP/IP interface redundancy support	Yes
Maximum number of PROFIBUS-DP network (using master modules PROFIBUS-DP)	4
PROFIBUS-DP network redundancy support	Yes
Redundancy support (half-clusters)	Yes
Hot Swap support	Yes
Event oriented data reporting (SOE)	Yes
Protocol	DNP3
Maximum Event Queue Size	1000
Web pages development (available through the HTTP protocol)	No

	NX3030
One Touch Diag (OTD)	Yes
Electronic Tag on Display (ETD)	Yes

Table 3: Common Features

Notes:

Real Time Clock (RTC): The retention time, time that the real time clock will continue to update the date and time after a CPU power down, is 15 days for operation at 25 °C. At the maximum product temperature, the retention time is reduced to 10 days.

Maximum number of I/O modules on bus: The maximum number of I/O modules refers to the sum of all modules on the local bus and expansions.

Event Log (SOE): Data types are found in the DNP3 Device Profile.

5.2. Standards and Certifications

Standards and Certifications	
IEC	<p>61131-2: Industrial-process measurement and control - Programmable controllers - Part 2: Equipment requirements and tests</p> <p>61131-3: Programmable controllers - Part 3: Programming languages</p>
	DNV Type Approval – DNV-CG-0339 (TAA000013D)
CE	<p>2014/30/EU (EMC)</p> <p>2014/35/EU (LVD)</p> <p>2011/65/EU and 2015/863/EU (ROHS)</p>
UK CA	<p>S.I. 2016 No. 1091 (EMC)</p> <p>S.I. 2016 No. 1101 (Safety)</p> <p>S.I. 2012 No. 3032 (ROHS)</p>
	<p>UL/cUL Listed – UL 61010-1</p> <p>UL 61010-2-201 (file E473496)</p>
EAC	<p>TR 004/2011 (LVD)</p> <p>CU TR 020/2011 (EMC)</p>

Table 4: Standards and Certifications

5.3. Memory

	NX3030
Addressable input variables memory (%I)	96 Kbytes
Addressable output variables memory (%Q)	96 Kbytes
Direct representation variable memory (%M)	64 Kbytes
Symbolic variable memory	6 Mbytes
Persistent or Retain symbolic variables memory	112 Kbytes
Full Redundant Data Memory	736 Kbytes
Direct representation input variable memory (%I)	80 Kbyte
Direct representation output variable memory (%Q)	80 Kbytes
Direct representation variable memory (%M)	64 Kbytes
Symbolic variable memory	512 Kbytes
Program memory	8 Mbytes
Source code memory (backup)	120 Mbytes
User files memory	32 Mbytes

Table 5: Memory

5.4. Protocols

	NX3030	Interface
Open Protocol	Yes	COM1 / COM2
MODBUS RTU Master	Yes	COM1 / COM2
MODBUS RTU Slave	Yes	COM1 / COM2
MODBUS TCP Client	Yes	NET1 / NET2
MODBUS TCP Server	Yes	NET1 / NET2
MODBUS RTU over TCP Client	Yes	NET1 / NET2
MODBUS RTU over TCP Server	Yes	NET1 / NET2
CANopen Master	No	-
CANopen Slave	No	-
CAN low level	No	-
SAE J-1939	No	-
OPC DA Server	Yes	NET1 / NET2
OPC UA Server	Yes	NET1 / NET2
EtherCAT Master	Yes	NET1 / NET2
SNMP Agent	Yes	NET1 / NET2
SOE (Event-oriented data)	Yes	NET1 / NET2
IEC 60870-5-104 Server	Yes	NET1 / NET2
EtherNet/IP Scanner	Yes	NET1 / NET2
EtherNet/IP Adapter	Yes	NET1 / NET2
MQTT Client	Yes	NET1 / NET2
SNTP Client (for clock synchronism)	Yes	NET1 / NET2
PROFINET Controller	Yes	NET1 / NET2
PROFINET Device	No	-

Table 6: Protocols

Note:

PROFINET Controller: Enabled for use without CPU redundancy and in a simple network (without a ring) with up to 8 devices. For larger applications, consult technical support.

5.5. Serial Interfaces

5.5.1. COM 1

COM 1	
Connector	Shielded female DB9
Physical interface	RS-232C
Modem signals	RTS, CTS, DCD
Baud rate	200, 300, 600, 1200, 1800, 2400, 4800, 9600, 19200, 38400, 57600, 115200 bps
Isolation	
Logic to Serial Port	Not isolated
Serial Port to protection earth 	1000 Vac / 1 minute

Table 7: COM 1 Serial Interface Features

5.5.2. COM 2

COM 2	
Connector	Shielded female DB9
Physical interface	RS-422 or RS-485 (depending on the selected cable)
Communication direction	RS-422: full duplex RS-485: half duplex
RS-422 max. transceivers	11 (1 transmitter and 10 receivers)
RS-485 max. transceivers	32
Termination	Yes (optional via cable selection)
Baud rate	200, 300, 600, 1200, 1800, 2400, 4800, 9600, 19200, 38400, 57600, 115200 bps
Isolation	
Logic to Serial Port	1000 Vac / 1 minute
Serial Port to protection earth 	1000 Vac / 1 minute

Table 8: COM 2 Serial Interface Features

Notes:

Physical interface: Depending on the configuration of the used cable, it's possible to choose the kind of physical interface: RS-422 or RS-485. The list of cables can be found at [Related products](#) section.

RS-422 maximum transceivers: It's the maximum number of RS-422 interfaces that can be used on the same bus.

RS-485 maximum transceivers: It's the maximum number of RS-485 interfaces that can be used on the same bus.

5.6. Ethernet interfaces

5.6.1. NET 1

	NET 1
Connector	Shielded female RJ45
Auto crossover	Yes
Maximum cable length	100 m
Cable type	UTP or ScTP, category 5
Baud rate	10/100 Mbps
Physical layer	10/100 BASE-TX (Full Duplex)
Data link layer	LLC (Logical Link Control)
Network layer	IP (Internet Protocol)
Transport layer	TCP (Transmission Control Protocol) UDP (User Datagram Protocol)
Diagnostic	LEDs - green (speed), yellow (link/activity)
Isolation Ethernet interface to logic and earth	1500 Vac / 1 minute

Table 9: Ethernet NET 1 Interface Features

The NET 1 Interface is the interface used for programming using the MasterTool IEC XE tool.

5.6.2. NET 2

	NET 2
Connector	Shielded female RJ45
Auto crossover	Yes
Maximum cable length	100 m
Cable type	UTP or ScTP, category 5
Baud rate	10/100 Mbps
Physical layer	10/100 BASE-TX (Full Duplex)
Data link layer	LLC (Logical Link Control)
Network layer	IP (Internet Protocol)
Transport layer	TCP (Transmission Control Protocol) UDP (User Datagram Protocol)
Diagnostic	LEDs - green (speed), yellow (link/activity)
Isolation Ethernet interface to logic and earth	1500 Vac / 1 minute
Ethernet interface to Ethernet inter- face	1500 Vac / 1 minute

Table 10: Ethernet NET 2 Interface Features

5.7. Memory Card Interface

	Memory Card
Maximum Capacity	32 Gbytes
Minimum Capacity	2 Gbytes
Type	MiniSD
File System	FAT32
Remove card safely	Yes, by pressing MS switch

Table 11: Memory Card Interface Features

Notes:

Maximum Capacity: The memory card capacity must be less than or equal to this limit for correct operation on Nexto CPU, otherwise the Nexto CPU may not detect the memory card or even present problems during data transfer.

Minimum Capacity: The memory card capacity must be greater than or equal to this limit for correct operation on Nexto CPU, otherwise the Nexto CPU may not detect the memory card or even present problems during data transfer.

File System: It is recommended to format the memory card using the Nexto CPU, otherwise it may result in performance loss in the memory card interface.

5.8. Environmental Characteristics

	NX3030
Current consumption on the power supply rail	1000 mA
Dissipation	5 W
Operating temperature	0 to 60 °C
Storage temperature	-25 to 75 °C
Relative humidity	5% to 96%, non-condensing
Conformal coating	Yes
IP Level	IP 20
Module dimensions (W x H x D)	36,00 x 114,63 x 115,30 mm
Package dimensions (W x H x D)	44,00 x 122,00 x 147,00 mm
Weight	350 g
Weight with package	400 g

Table 12: Environmental Characteristics

Notes:

Conformal coating of electronic circuits: The covering of electronic circuits protects internal parts of the product against moisture, dust and other harsh elements to electronic circuits.

5.9. Performance

Instruction	Language	Variables	Instruction Times (μ s)
1000 Contacts	LD	BOOL	6
1000 Divisions	ST	INT	43
		REAL	81
	LD	INT	43
		REAL	81
1000 Multiplications	ST	INT	15
		REAL	23
	LD	INT	15
		REAL	23
1000 Sums	ST	INT	15
		REAL	23
	LD	INT	15
		REAL	23
1000 PID	ST	REAL	< 5000

Table 13: Instruction Times

6. CPU redundancy

Nexto Series offers CPU redundancy. Redundant CPUs can be located in different racks (known as half-clusters). In the redundant architecture, the system will have a running CPU (active CPU) and another CPU in reserve. In case of failure in the main controller, the standby CPU is able to automatically take control of the application. This means that critical processes are not affected by hardware failures in the control system. The result is increased productivity and minimized downtime.

Communication between the CPUs is done at the end of each cycle, through two high-speed redundancy links.

More information about configuration and use of CPU redundancy features can be found in NX3030 CPU User Manual - MU214615.

6.1. Half-Cluster Redundancy

This redundancy option uses two racks with a CPU and a redundancy link module in each rack. In this case, each rack is called a "half-cluster". Each half-cluster can also have one or more fieldbus master modules which are responsible for communicating with all remote I/O. When an error occurs with a half-cluster, the spare half-cluster takes over and its fieldbus master module becomes its active master. This application is easy to configure and does not require the user to carry out special programming or parameterization. In this redundant mode, the CPU and the redundancy link module must be placed side by side. The figure below illustrates an example of a rack with a half-cluster redundant topology:

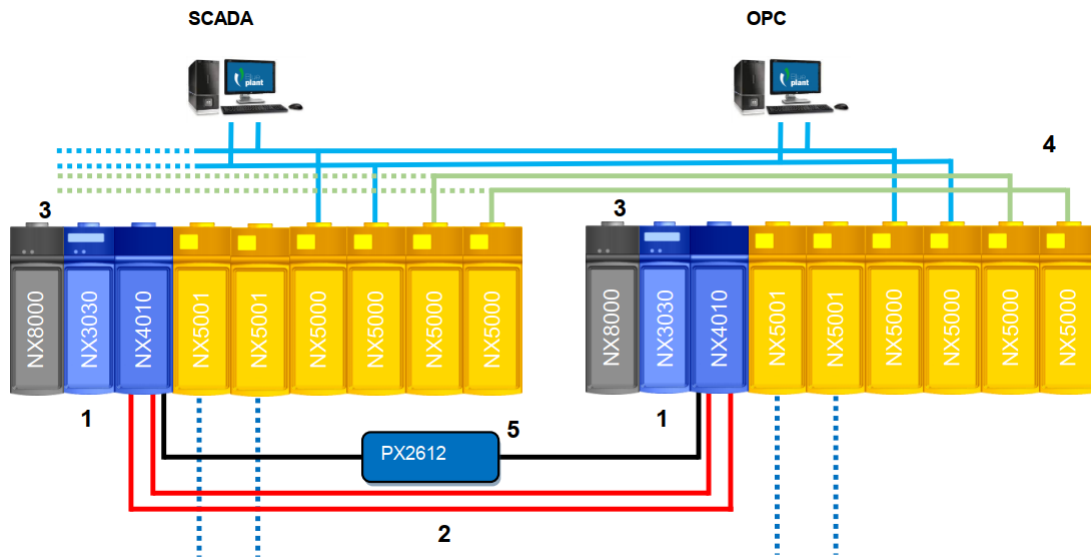

Figure 1: Half-Cluster Redundancy

Chart Notes:

- 1 - At the core of a two half-cluster redundant system, there is a pair of redundant CPUs.
- 2 - Links between two half-clusters have two channels. Thus, any failures in a single channel will not affect the system.
- 3 - The configuration of each half-cluster must be identical.
- 4 - This example presents network modules with Ethernet-based protocols. There are two network modules for each purpose: a control network and a supervision network for SCADA.
- 5 - The PX2612 redundancy panel is optional for half-cluster redundancy. It must be used when the PX2612 panel redundancy option is selected when creating a project in the MasterTool IEC XE wizard.

7. Compatibility with Other Products

To develop an application for Nexto Series CPUs, it is necessary to check the version of MasterTool IEC XE. The following table shows the minimum version required (where the controllers were introduced) and the respective firmware version at that time:

Nexto Series CPUs	MasterTool IEC XE	Firmware version
NX3010, NX3020, NX3030	1.00 to 2.09	1.2.0.9 to 1.7.0.14
NX3010, NX3020, NX3030	3.00 or above	1.8.3.0 or above

Table 14: Compatibility with other products

Additionally, along the development roadmap of MasterTool IEC XE some features may be included (like special Function Blocks, etc...), which can introduce a requirement of minimum firmware version. During the download of the application, MasterTool IEC XE checks the firmware version installed on the controller and, if it does not meet the minimum requirement, will show a message requesting to update. The latest firmware version can be downloaded from Altus website, and it is fully compatible with previous applications.

8. Physical Dimensions

Dimensions in mm.

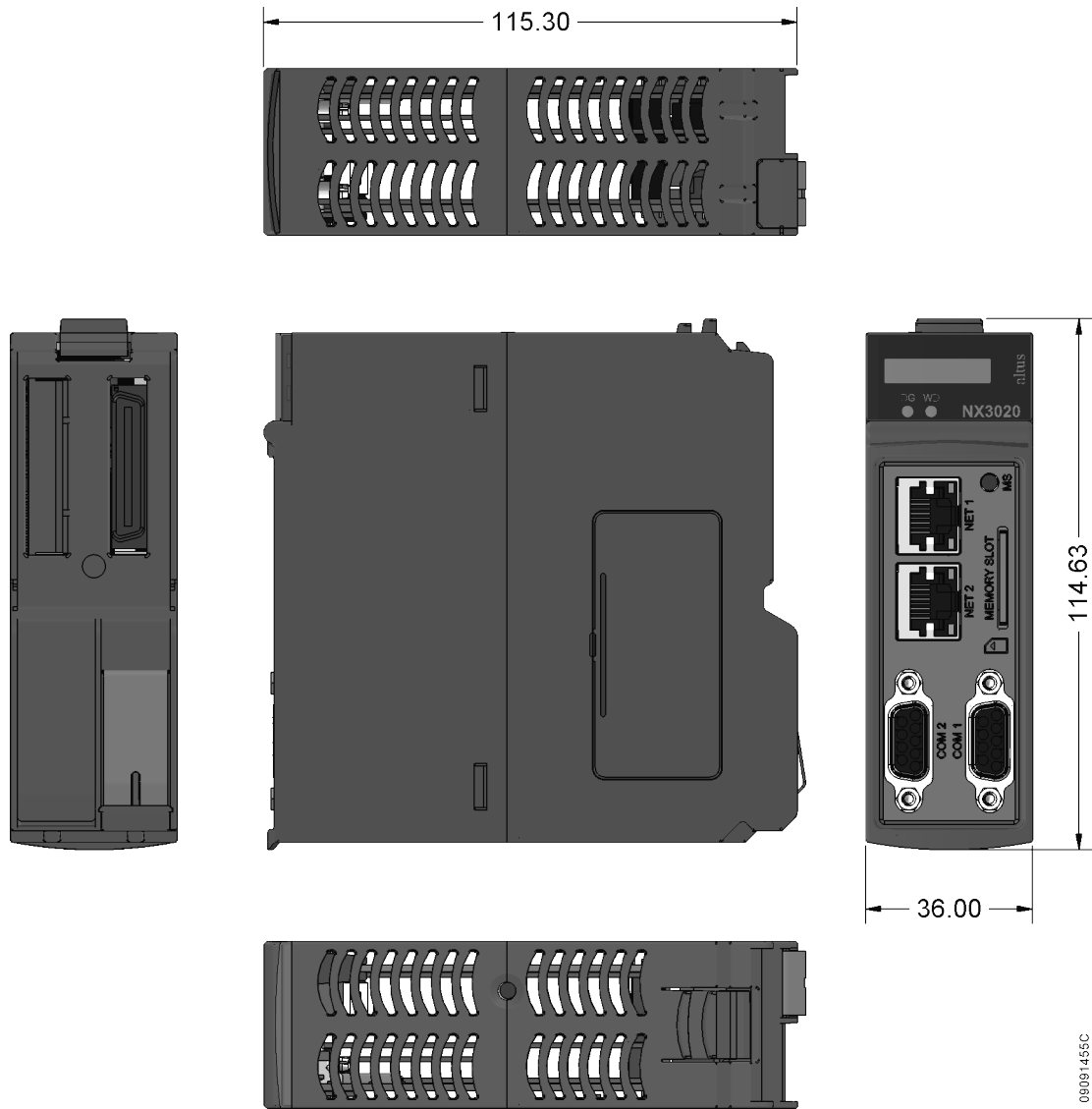

Figure 2: CPU Physical Dimensions

9. Installation

For the correct installation of this product, it is necessary to use a rack (backplane rack) and it must be carried out according to the mechanical and electrical installation instructions that follow.

9.1. Product Identification

This product has some parts that must be observed before installation and use. The following figure identifies each of these parts.

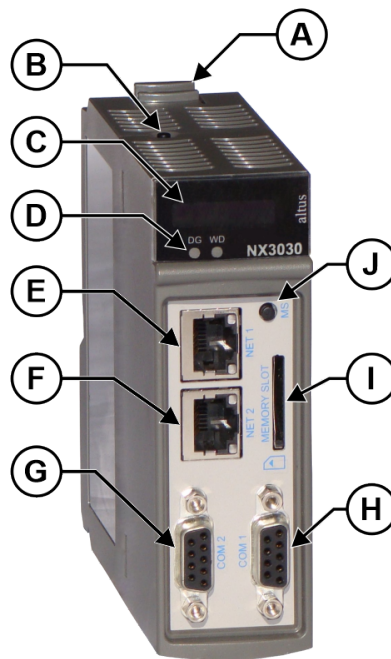

Figure 3: NX3030

- Ⓐ Fixing lock.
- Ⓑ Diagnostic switch.
- Ⓒ Status and diagnostic display.
- Ⓓ Diagnostic and watchdog LEDs.
- Ⓔ RJ45 connector for Ethernet communication.
- Ⓕ RJ45 connector for Ethernet communication.
- Ⓖ Female DB9 connector for RS-485/RS-422.
- Ⓗ Female DB9 connector RS-232C.
- Ⓘ MiniSD card interface.
- ⓵ Switch to remove miniSD card safely.

The product has in its mechanics a label that identifies it and in it are presented some symbols whose meaning is described below:

- ⚠ Attention! Before using the equipment and installing, read the documentation.
- ⎓ Direct Current.

9.2. Electrical Installation

The figure below illustrates the electrical diagram of the CPU installed in a Nexto Series rack. The layout of the connectors and terminals in the figure is merely illustrative.

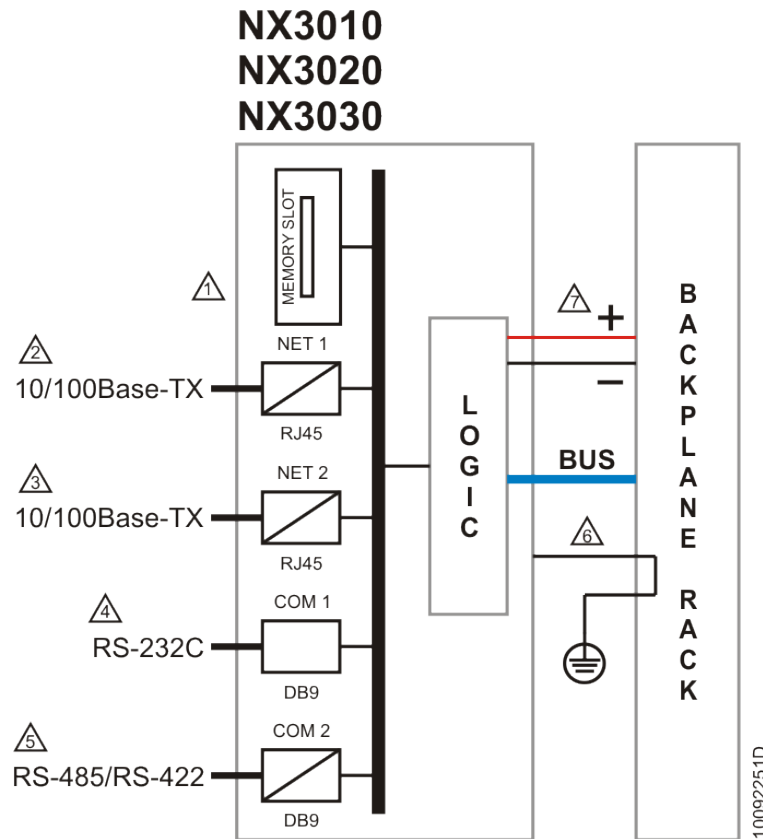

Figure 4: Electrical Diagram of Nexto Series NX3010, NX3020 and NX3030 CPUs

Diagram Notes:

- ① MiniSD card interface.
- ② Ethernet 10/100Base-TX standard interface.
- ③ Ethernet 10/100Base-TX standard interface (only for NX3020 and NX3030).
- ④ Serial RS-232C standard interface.
- ⑤ Serial RS-485/RS-422 standard interface. The choice of physical interface used depends on the cable.
- ⑥ The module is grounded through the Nexto Series backplane racks.
- ⑦ The module power supply is derived from the connection to the backplane rack, not requiring external connections.
- ⊕ Protective conductor terminal.

9.3. Mechanical Assembly

This product must be positioned in position 2 of the Nexto Series rack. Two sequential positions are required, this means that it will occupy positions 2 and 3 of a rack. Requiring an NX8000 - Power Supply Module, in positions 0 and 1 of the rack. The mechanical assembly of this controller is described in NX3030 CPU User Manual – MU214615.

ATTENTION

Products with broken warranty seal are not covered in warranty.

CAUTION



The device is sensitive to static electricity (ESD). Always touch in a metallic grounded object before handling it.

DANGER



Nexto Series can operate with voltage up to 250 Vac. Special care must be taken during the installation, which should only be done by qualified technical personnel. Do not touch on the wiring field when in operation.

10. Manuals

For further technical details, configuration, installation and programming, the table below should be consulted.

The table below is only a guide of some relevant documents that can be useful during the use, maintenance, and programming of this product.

Code	Description	Language
CE114000	Nexto Series – Technical Characteristics	English
CT114000	Série Nexto – Características Técnicas	Portuguese
CE114102	NX3030 Technical Characteristics	English
CT114102	Características Técnicas NX3030	Portuguese
CE114200	NX8000 Power Supply Module Technical Characteristics	English
CT114200	Características Técnicas Fonte de Alimentação NX8000	Portuguese
CE114700	Nexto Series Backplane Racks Technical Characteristic	English
CT114700	Características Técnicas dos Bastidores da Série Nexto	Portuguese
CE114810	Nexto Series Accessories for Backplane Rack Technical Characteristics	English
CT114810	Características Técnicas Acessórios para Bastidor Série Nexto	Portuguese
CE114900	NX4010 Redundancy Link Module Technical Characteristics	English
CT114900	Características Técnicas do Módulo de Redundância NX4010	Portuguese
CE114902	Nexto Series PROFIBUS-DP Master Technical Characteristics	English
CT114902	Características Técnicas do Mestre PROFIBUS-DP da Série Nexto	Portuguese
CE114903	Nexto Series Ethernet Module Technical Characteristics	English
CT114903	Características Técnicas Módulo Ethernet Série Nexto	Portuguese
CE114908	NX5110 and NX5210 PROFIBUS-DP Heads Technical Characteristics	English
CT114908	Características Técnicas Interfaces Cabeça PROFIBUSDP NX5110 e NX5210	Portuguese
CS114908	Especificaciones y Configuraciones PROFIBUS-DP Interfaz Cabezas NX5110 y NX5210	Spanish
CT112500	Características Técnicas do Painel de Controle de Redundância PX2612	Português
MU214600	Nexto Series User Manual	English
MU214000	Manual de Utilização Série Nexto	Portuguese
MU214615	NX3030 CPU User Manual	English
MU214103	Manual de Utilização UCP NX3030	Portuguese
MU299609	MasterTool IEC XE User Manual	English
MU299048	Manual de Utilização MasterTool IEC XE	Portuguese
MP399609	MasterTool IEC XE Programming Manual	English
MP399048	Manual de Programação MasterTool IEC XE	Portuguese
MU214601	NX5001 PROFIBUS DP Master User Manual	English
MU214001	Manual de Utilização Mestre PROFIBUS-DP NX5001	Portuguese
MU214608	Nexto PROFIBUS-DP Head Utilization Manual	English
MU214108	Manual de Utilização da Cabeça PROFIBUS-DP Nexto	Portuguese
MU219000	Ponto Series Utilization Manual	English
MU209000	Manual de Utilização da Série Ponto	Portuguese
MU209508	Manual de Utilização Cabeça PROFIBUS PO5063V1 e Cabeça Redundante PROFIBUS PO5063V5	Portuguese
MU219511	PO5064 PROFIBUS Head and PO5065 Redundant PROFIBUS Head Utilization Manual	English

Code	Description	Language
MU209511	Manual de Utilização Cabeça PROFIBUS PO5064 e Cabeça Redundante PROFIBUS PO5065	Portuguese
MU209020	Manual de Utilização Rede HART sobre PROFIBUS	Portuguese
MU223603	IEC 60870-5-104 Server Device Profile Document	English
MU214603	Nexto Series HART Manual	English
MU214606	MQTT User Manual	English
MU214609	OPC UA Server for Altus Controllers User Manual	English
MU214610	Advanced Control Functions User Manual	English
MU214621	Nexto Series PROFINET Manual	English
NAP151	Utilização do Tunneller OPC	Portuguese

Table 15: Related Documents