

1. Product Description

Nexto Series programmable controllers are the ultimate solution for industrial automation and system control. With high technology embedded, the products of the family are able to control, in a distributed and redundant way, complex industrial systems, machines, high performance production lines and the most advanced processes of Industry 4.0. Modern and high-speed, the Nexto series uses cutting-edge technology to provide reliability and connectivity, helping to increase the productivity of different businesses.

Compact, robust and with high availability, the series products have excellent processing performance and rack expansion possibilities. Its architecture allows easy integration with supervision, control and field networks, in addition to PLC redundancy. The series equipment also offers advanced diagnostics and hot swapping, minimizing or eliminating maintenance downtime and ensuring a continuous production process.



Its main features are:

- Up to 32 Kbytes of %I points and 32 Kbytes of %Q points
- Large memory capacity for user application and user data
- Up to 7.5 Kbytes of retain or persistent memory
- High-speed 32-bit processing
- Floating point unit
- Up to 1 serial port
- Up to 1 Ethernet interface at front panel
- Enhanced diagnostics services
- System messages log
- OPC DA/UA, PROFINET, SNMP and EtherNet/IP protocols
- clock synchronization via SNTP
- Web server features
- Integrated power supply
- Integrated digital I/O
- Fast counter and Outputs
- One Touch Diag
- IEC 61131-3 compliant
- Real-time clock (RTC)
- Compact and modern design
- Free of moving parts (fans, active cooling, etc.)

2. Ordering Information

2.1. Included Items

The product package contains the following items:

- NX3003 module
- 12-terminal connector with fixing
- 18-terminal connector with fixing

2.2. Product Code

The following code should be used to purchase the product:

Code	Description
NX3003	CPU, 1 Ethernet port, 1 serial channel, 14 digital inputs, 10 digital outputs, local I/O modules support and power supply integrated

Table 1: Product Code

3. Related Products

The following products must be purchased separately when necessary:

Code	Description
MT8500	MasterTool IEC XE
AL-2600	RS-485 network branch and terminator
AL-2306	RS-485 cable for MODBUS or CAN network
AL-1763	CMDB9-Terminal Block Cable
AL-1766	CFDB9-Terminal Block Cable
NX9101	32 GB microSD memory card with miniSD and SD adapters
NX9202	RJ45-RJ45 2 m Cable
NX9205	RJ45-RJ45 5 m Cable
NX9210	RJ45-RJ45 10 m Cable
NX9405	12-terminal connector with fixing
NX9406	18-terminal connector with fixing
NX9020	2-Slot base for panel assembly
NX9000	8-Slot Backplane Rack
NX9001	12-Slot Backplane Rack
NX9002	16-Slot Backplane Rack
NX9003	24-Slot Backplane Rack
NX9010	8-Slot Backplane Rack (No Hot Swap)

Table 2: Related Products

Notes:

MT8500: MasterTool IEC XE is available in four different versions: LITE, BASIC, PROFESSIONAL and ADVANCED. For more details, please check MasterTool IEC XE User Manual - MU299609.

AL-2600: This module is used for branch and termination of RS-422/485 networks. For each network node, an AL-2600 is required. The AL-2600 that is at the ends of network must be configured with termination, except when there is a device with active internal termination, the rest must be configured without termination.

AL-2306: Two shielded twisted pairs cable without connectors, used for networks based on RS-485 or CAN.

AL-1763: Cable with one DB9 male connector and terminal block for communication between CPUs of the Nexto Series and products with RS-485/RS-422 standard terminal block.

AL-1766: Cable with a female DB9 connector and terminals for communication between HMI P2 and Nexto Xpress/NX3003 controllers.

NX9202/NX9205/NX9210: Cables used for Ethernet communication and to interconnect the bus expansion modules.

NX9405: 12 terminal connector used on NX3003.

NX9406: 18 terminal connector used on NX3003.

NX9020: 2 slot base for panel assembly. Used by NX3003, NX3004 and NX3005 CPUs, which don't require I/O modules on the bus.

4. Innovative Features

Nexto Series brings to the user many innovations regarding utilization, supervision and system maintenance. These features were developed focusing a new concept in industrial automation.



Battery Free Operation: Nexto Series does not require any kind of battery for memory maintenance and real time clock operation. This feature is extremely important because it reduces the system maintenance needs and allows the use in remote locations where maintenance can be difficult to be performed. Besides, this feature is environmentally friendly.



Easy Plug System: Nexto Series has an exclusive method to plug and unplug I/O terminal blocks. The terminal blocks can be easily removed with a single movement and with no special tools. In order to plug the terminal block back to the module, the frontal cover assists the installation procedure, fitting the terminal block to the module.



Multiple Block Storage: Several kinds of memories are available to the user in Nexto Series CPUs, offering the best option for any user needs. These memories are divided in volatile memories and non-volatile memories. For volatile memories, Nexto Series CPUs offer addressable input (%I), addressable output (%Q), addressable memory (%M), data memory and redundant data memory. For applications that require non-volatile functionality, Nexto Series CPUs bring retain addressable memory (%Q), retain data memory, persistent addressable memory (%Q), persistent data memory, program memory, source code memory, CPU file system (doc, PDF, data) and memory card interface.



One Touch Diag: One Touch Diag is an exclusive feature that Nexto Series brings to PLCs. With this new concept, the user can check diagnostic information of any module present in the system directly on CPU's graphic display with one single press in the diagnostic switch of the respective module. OTD is a powerful diagnostic tool that can be used offline (without supervisor or programmer), reducing maintenance and commissioning times.

OFD – On Board Full Documentation: Nexto Series CPUs are capable of storing the complete project documentation in its own memory. This feature can be very convenient for backup purposes and maintenance, since the complete information is stored in a single and reliable place.

ETD – Electronic Tag on Display: Another exclusive feature that Nexto Series brings to PLCs is the Electronic Tag on Display. This new functionality brings the process of checking the tag names of any I/O pin or module used in the system directly to the CPU's graphic display. Along with this information, the user can check the description, as well. This feature is extremely useful during maintenance and troubleshooting procedures.

DHW – Double Hardware Width: Nexto Series modules were designed to save space in user cabinets or machines. For this reason, Nexto Series delivers two different module widths: Double Width (two backplane rack slots are required) and Single Width (only one backplane rack slot is required). This concept allows the use of compact I/O modules with a high-density of I/O points along with complex modules, like CPUs, fieldbus masters and power supply modules.

High-speed CPU: All Nexto Series CPUs were designed to provide an outstanding performance to the user, allowing the coverage of a large range of applications requirements.



iF Product Design Award 2012: Nexto Series was the winner of iF Product Design Award 2012 in industry + skilled trades group. This award is recognized internationally as a seal of quality and excellence, considered the Oscars of the design in Europe..

5. Product Features

5.1. Common General Features

	NX3003
Backplane rack occupation	2 sequential slots
Power supply integrated	Yes
Ethernet TCP/IP local interface	1
Serial Interface	1
CAN Interface	No
USB Port Host	No
Memory card interface	No
Integrated I/O	
Digital Inputs	10
Fast Inputs	4
Digital Outputs	6
Fast Outputs	4
Max. number of high-speed counters	4
Max. number of external interruptions	4
Max. number of PTO outputs	4
Max. number of VFO/PWM outputs	4
Real time clock (RTC)	Yes Resolution of 1 ms and maximum variance of 2 s per day.
Watchdog	Yes
Status and diagnostic indication	Graphic display System Web Page CPU's internal memory
Programming languages	Structured Text (ST) Ladder Diagram (LD) Sequential Function Chart (SFC) Function Block Diagram (FBD) Continuous Function Chart (CFC)
Tasks	Cyclic (periodic) Triggered by event (software interruption) Triggered by external event (hardware interruption) Freewheeling (continuous) Triggered by status (software interruption)
Online changes	Yes
Maximum number of tasks	16
Maximum number of expansion bus	0
Bus expansion redundancy support	No
Maximum number of I/O modules on the bus	10
Maximum number of additional Ethernet TCP/IP interface modules	0
Ethernet TCP/IP interface redundancy support	No
Maximum number of PROFIBUS-DP network (using master modules PROFIBUS-DP)	0

NX3003	
PROFIBUS-DP network redundancy support	No
Redundancy support (half-clusters)	No
Hot Swap support	No
Event oriented data reporting (SOE)	No
Protocol	-
Maximum event queues size	-
Web pages development (available through the HTTP protocol)	No
One Touch Diag (OTD)	Yes
Electronic Tag on Display (ETD)	Yes

Table 3: General Features

Note:

Real Time Clock (RTC): The retention time, time that the real time clock will continue to update the date and time after a CPU power down, is 15 days for operation at 25 °C. At the maximum product temperature, the retention time is reduced to 10 days.

Maximum number of I/O modules on the bus: The maximum number of I/O modules refers to the sum of all modules on the local bus and expansions.

5.2. Standards and Certifications

Standards and Certifications	
IEC	<p>61131-2: Industrial-process measurement and control - Programmable controllers - Part 2: Equipment requirements and tests</p> <p>61131-3: Programmable controllers - Part 3: Programming languages</p>
CE	<p>2014/30/EU (EMC)</p> <p>2014/35/EU (LVD)</p> <p>2011/65/EU and 2015/863/EU (ROHS)</p>
UK CA	<p>S.I. 2016 No. 1091 (EMC)</p> <p>S.I. 2016 No. 1101 (Safety)</p> <p>S.I. 2012 No. 3032 (ROHS)</p>
cUL LISTED	<p>UL/cUL Listed – UL 61010-1</p> <p>UL 61010-2-201 (file E473496)</p>

Table 4: Standards and Certifications

5.3. Memory

	NX3003
Addressable input variables memory (%I)	32 Kbytes
Addressable output variables memory (%Q)	32 Kbytes
Addressable variables memory (%M)	16 Kbytes
Symbolic variables memory	2 Mbytes
Persistent or Retain symbolic variables memory	7.5 Kbytes
Total redundant data memory	-
Addressable input variables memory (%I)	-
Addressable output variables memory (%Q)	-
Addressable variables memory (%M)	-
Symbolic variables memory	-
Program memory	3 Mbytes
Source code memory (backup)	32 Mbytes
User files memory	16 Mbytes

Table 5: Memory

5.4. Protocols

	NX3003	Interface
Open Protocol	Yes	COM1
MODBUS RTU Master	Yes	COM1
MODBUS RTU Slave	Yes	COM1
MODBUS TCP Client	Yes	NET1
MODBUS TCP Server	Yes	NET1
MODBUS RTU over TCP Client	Yes	NET1
MODBUS RTU over TCP Server	Yes	NET1
CANopen Master	No	-
CANopen Slave	No	-
CAN low level	No	-
SAE J-1939	No	-
OPC DA Server	Yes	NET1
OPC UA Server	Yes	NET1
EtherCAT Master	No	-
SNMP Agent	Yes	NET1
SOE (Event-oriented data)	No	-
IEC 60870-5-104 Server	No	-
EtherNet/IP Scanner	Yes	NET1
EtherNet/IP Adapter	Yes	NET1
MQTT Client	Yes	NET1

	NX3003	Interface
SNTP Client (for clock synchronism)	Yes	NET1
PROFINET Controller	Yes	NET1
PROFINET Device	No	-

Table 6: Protocols

Note:

PROFINET Controller: Enabled for use on a simple (not ring) network with up to 8 devices. For larger applications, consult technical support.

5.5. Serial Interface

5.5.1. COM 1

	COM1
Connector	Terminals
Physical interface	RS-485
Communication direction	RS-485: half duplex
RS-485 maximum transceivers	32
Termination	Yes (optional through parameter)
Baud rate	200, 300, 600, 1200, 1800, 2400, 4800, 9600, 19200, 38400, 57600, 115200 bps
Protocols	MODBUS RTU Master/Slave Open protocol
Isolation Logic to Serial Port Serial Port to protection earth 	Not isolated 1000 Vac / 1 minute

Table 7: COM 1 Serial Interface Features

Note:

RS-485 maximum transceivers: It is the maximum number of RS-485 interfaces that can be used on the same bus.

5.6. Ethernet interface

5.6.1. NET 1

	NET 1
Connector	Shielded female RJ45
Auto crossover	Yes
Maximum cable length	100 m
Cable type	UTP or ScTP, category 5
Baud rate	10/100 Mbps
Physical layer	10/100 BASE-TX (Full Duplex)
Data link layer	LLC (Logical Link Control)
Network layer	IP (Internet Protocol))
Transport layer	TCP (Transmission Control Protocol) UDP (User Datagram Protocol)
Diagnostic	LEDs - green (speed), yellow (link/activity)
Isolation Ethernet interface to Se- rial Port	1500 Vac / 1 minute

Table 8: Ethernet NET 1 Interface Features

5.7. Power Supply

	NX3003
Nominal input voltage	24 Vdc
Maximum output power	10 W
Maximum output current	2 A
Input voltage	19.2 to 30 Vdc
Maximum input current (in- rush)	40 A
Maximum input current	1 A
Maximum input voltage inter- ruption	1 ms @ 24 Vdc
Isolation Input to logic Input to protective earth ⊕	1000 Vac / 1 minute 1000 Vac / 1 minute
Wire size	0.5 mm ²
Polarity inversion protection	Yes
Internal auto recovery fuse	No
Output short-circuit protec- tion	No
Overcurrent protection	No

Table 9: Power Supply Features

5.8. Digital inputs

NX3003	
Input type	Sink type 1
Number of inputs	10
Connector configuration	I4, I5, I6, I7, I8, I9, I10, I11, I12 and I13
Input voltage	24 Vdc 15 to 30 Vdc for logic level 1 0 to 5 Vdc for logic level 0
Input impedance	4.95 k Ω
Input maximum current	6.2 mA @ 30 Vdc
Input state indication	Yes
ETD	No
Input update time	
Normal mode	1 ms
Counter mode	2.5 ms
Input filter	100 μ s – by hardware 2 ms to 255 ms – by software
Isolation	
Input to logic	1500 Vac / 1 minute
Input to fast outputs	1000 Vac / 1 minute
Input to counters	1000 Vac / 1 minute
Input to Ethernet	1500 Vac / 1 minute
Input to power supply	1000 Vac / 1 minute
Input to protective earth 	1000 Vac / 1 minute

Table 10: Digital Inputs Features

Note:

Input filter: The input filter sampling is done in the MainTask (or through refresh function), therefore it is recommended to set values multiples of the task interval.

5.9. Fast Inputs

NX3003	
Number of fast inputs	4 (can be used as high-speed counter, external interrupt or normal input)
Max. number of high-speed counters	4
Max. number of external interrupts	4
Connector configuration	I0, I1, I2 and I3
Input voltage	24 Vdc 15 to 30 Vdc for logic level 1 0 to 5 Vdc for logic level 0
Input impedance	1.85 k Ω
Input maximum current	16.2 mA @ 30 Vdc
Configuration mode	1-input modes: Normal digital input External interrupt Up counter Down counter 2-input modes: Up/Down counter (A count up, B count down) Up/Down counter (A count, B direction) Quadrature 2x Quadrature 4x
Counting direction control	Hardware only
Counting input detection edge	Rising edge, active at logic level 1 (except for quadrature 4x, where it counts on both edges)
Data format	Signed 32-bit integer
Operation limit	From - 2,147,483,648 to 2,147,483,647
Maximum input frequency	200 kHz
Minimum pulse width @ 24 Vdc	1 μ s
ETD	No
Isolation	
Fast input to power supply	Not isolated
Fast input to logic	1000 Vac / 1 minute
Fast input to normal outputs	1000 Vac / 1 minute
Fast input to normal inputs	1000 Vac / 1 minute
Fast input to Ethernet	1500 Vac / 1 minute
Fast input to protective earth 	1000 Vac / 1 minute

Table 11: Fast Inputs Features

Note:

Configuration mode: The configuration modes define I0, I1, I2 and I3 inputs behavior.

5.10. Digital Outputs

NX3003	
Common outputs number	6
Connector configuration	Q4, Q5, Q6, Q7, Q8 and Q9
Maximum current	1.5 A @ 30 Vdc by output 4 A @ 30 Vdc total
Output type	Transistor source
Switching time	200 μ s - off to on transition @ 30 Vdc 500 μ s - on to off transition @ 30 Vdc
Maximum switch frequency	250 Hz
State indication	Yes, can be seen through standard product screens
ETD	No
Protections	Yes, TVS diode at all transistor outputs
Operation voltage	19.2 to 30 Vdc
Output impedance	500 m Ω
Isolation	
Output to logic	1500 Vac / 1 minute
Output to fast outputs	1000 Vac / 1 minute
Output to fast inputs	1000 Vac / 1 minute
Output to Ethernet	1500 Vac / 1 minute
Output to power supply	1000 Vac / 1 minute
Output to protective earth	1000 Vac / 1 minute

Table 12: Digital Outputs Features

Note:

Switching time: Required to shut down an output, but it depends on the load. A load with low resistance results in a shorter switching time. The given time refers to the maximum time to disable an output connected to a resistive load of 12.5 k Ω , which is the maximum resistance allowable defined by IEC 61131 to digital outputs modules.

5.11. Fast Outputs

NX3003		
Number of fast outputs	4 (can be used as: VFO/PWM, PTO or normal output)	
Connector configuration	Q0, Q1, Q2 and Q3	
Maximum current	0.5 A @ 30 Vdc by output 2 A @ 30 Vdc total	
Output type	Transistor source	
Pulse generation maximum frequency	200 kHz @ 60 mA	
Minimum pulse width @ 24 Vdc	MINIMUM LOAD	MINIMUM PULSE TIME
	400 Ω	320 ns
State indication	Through symbolic variables	
Protections	TVS diode at all transistor outputs	
Operation voltage	19.2 to 30 Vdc	
Output impedance	700 mΩ	
Output modes	Normal digital output VFO/PWM PTO	
Functions executed by software	PTO	VFO/PWM
	Writing of number of pulses to be generated Writing of acceleration and deceleration number of pulses Start/end outputs operation Fast outputs diagnostics Fast outputs current state monitoring	Writing of the frequency value to be generated (1 Hz to 200 kHz). Writing of outputs duty cycle (1% to 100%) Start/end of outputs operations Fast outputs diagnostics
ETD	No	
Isolation		
Fast output to power supply	Not isolated	
Fast output to logic	1000 Vac / 1 minute	
Fast output to normal outputs	1000 Vac / 1 minute	
Fast output to normal inputs	1000 Vac / 1 minute	
Fast output to Ethernet	1500 Vac / 1 minute	
Fast output to protective earth Ⓧ	1000 Vac / 1 minute	

Table 13: Fast Outputs Features

5.12. Environmental Characteristics

NX3003	
Current consumption on the power supply rail	-
Dissipation	4 W
Operating temperature	0 to 60 °C
Storage temperature	-25 to 75 °C
Relative humidity operating and storage	5% to 96%, non-condensing
Conformal coating of electronic circuits	Yes
IP Level	IP 20
Module dimensions (W x H x D)	36.00 x 114.63 x 115.30 mm
Package dimensions (W x H x D)	44.00 x 122.00 x 147.00 mm
Weight	350 g
Weight with package	400 g

Table 14: Environmental Characteristics

Notes:

Conformal coating of electronic circuits: The covering of electronic circuits protects internal parts of the product against moisture, dust and other harsh elements to electronic circuits.

5.13. Performance

Instruction	Language	Variables	Instruction Times (μs)
1000 Contacts	LD	BOOL	9
1000 Divisions	ST	INT	53
		REAL	121
	LD	INT	53
		REAL	122
1000 Multiplications	ST	INT	19
		REAL	27
	LD	INT	19
		REAL	29
1000 Sums	ST	INT	19
		REAL	29
	LD	INT	19
		REAL	29
1000 PID	ST	REAL	<2485

Table 15: Instruction Times

6. Compatibility with Other Products

To develop an application for Nexto Series CPUs, it is necessary to check the version of MasterTool IEC XE. The following table shows the minimum version required (where the controllers were introduced) and the respective firmware version at that time:

Nexto Series CPUs	MasterTool IEC XE	Firmware version
NX3003	3.10 or above	1.7.0.0 or above

Table 16: Compatibility with other products

Additionally, along the development roadmap of MasterTool IEC XE some features may be included (like special Function Blocks, etc...), which can introduce a requirement of minimum firmware version. During the download of the application, MasterTool IEC XE checks the firmware version installed on the controller and, if it does not meet the minimum requirement, will show a message requesting to update. The latest firmware version can be downloaded from Altus website, and it is fully compatible with previous applications.

7. Physical Dimensions

Dimensions in mm.

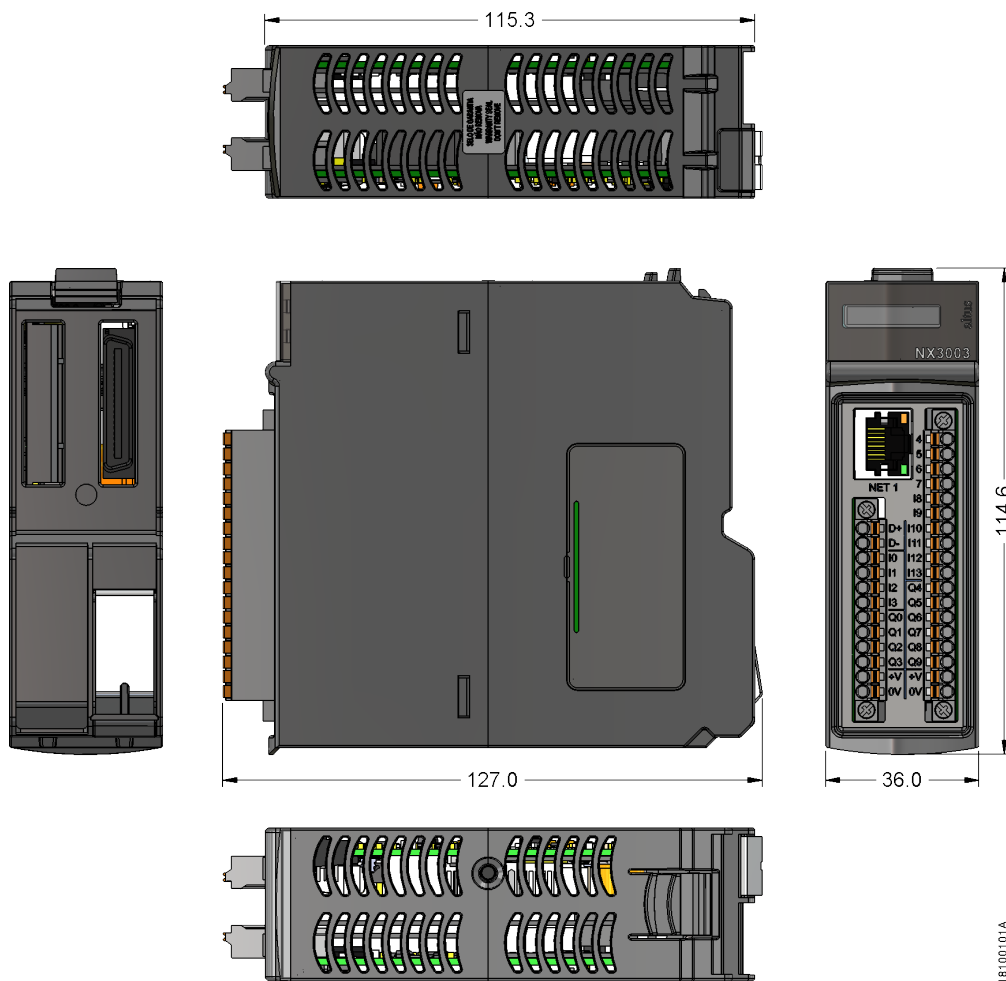

Figure 1: NX3003 CPU Physical Dimensions

8. Installation

For the correct installation of this product, it is necessary to use a rack (backplane rack) and it must be carried out according to the mechanical and electrical installation instructions that follow.

8.1. Product Identification

This product has some parts that must be observed before installation and use. The following figure identifies each of these parts.

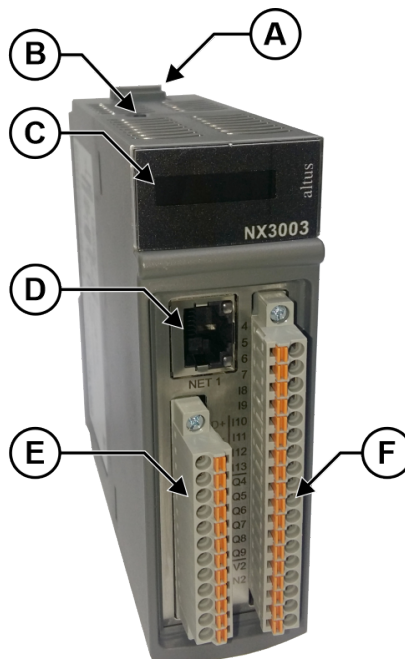

Figure 2: NX3003

- Ⓐ Fixing lock.
- Ⓑ Diagnostic switch.
- Ⓒ Status and diagnostic display.
- Ⓓ RJ45 connector for Ethernet communication.
- Ⓔ Power supply connector, I/O and RS-485.
- Ⓕ I/O connector.

The product has in its mechanics a label that identifies it and in it are presented some symbols whose meaning is described below:

⚠ Attention! Before using the equipment and installing, read the documentation.

⎓ Direct Current.

8.2. Electrical Installation

The figure below illustrates the electrical diagram of the product installed in a Nexto Series rack. The arrangement of connectors and terminals in the figure is merely illustrative.

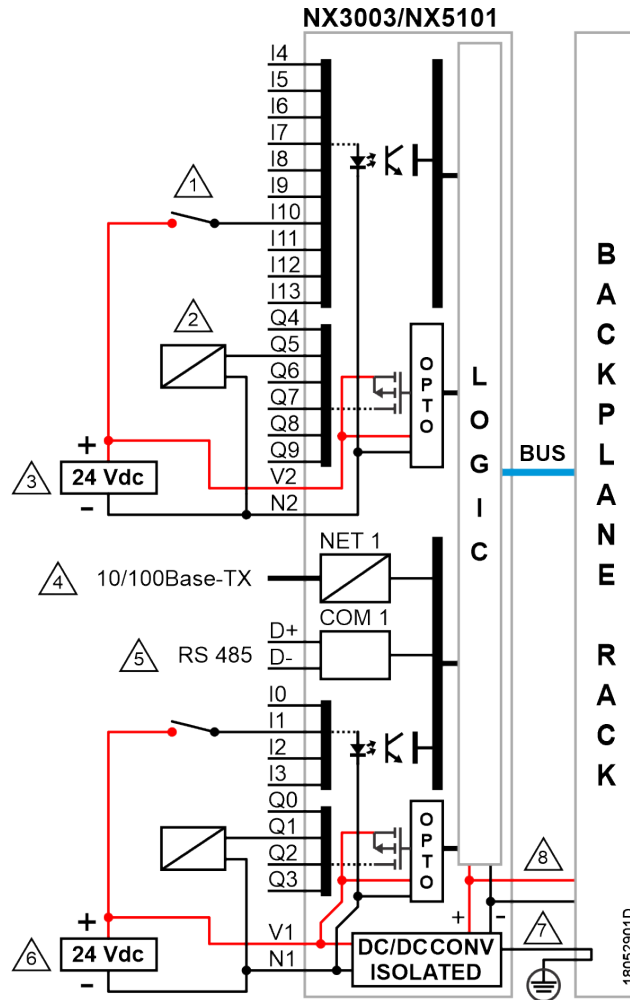









Figure 3: NX3003 CPU Electric Diagram

Diagram Notes:

-  Typical usage of sink digital inputs, N2 is the 0 Vdc common to input I4 to I13.
-  Typical usage of source digital outputs.
-  External power supply to supply the outputs Q4 to Q9, V2 is connected to +24 Vdc and N2 is connected to 0 Vdc.
-  Ethernet 10/100Base-TX standard interface.
-  Serial RS-485 interface (available only on NX3003). D+ and D- pins.
-  External power supply to supply the module and outputs Q0 to Q3, V1 is connected to +24 Vdc and N1 is connected to 0 Vdc. N1 is the common 0 Vdc input group I0 to I3.
-  The module feeds the others modules through rack connection.
-  Functional earth terminal.

8.3. Mechanical Assembly

This product must be inserted in the backplane rack position 0. It requires two sequential positions, this means that it uses positions 0 and 1 of the rack.

The mechanical assembly of this module is described in the NX3003 CPU User Manual – MU214618.

ATTENTION

Products with broken warranty seal are not covered in warranty.

CAUTION



The device is sensitive to static electricity (ESD). Always touch in a metallic grounded object before handling it.

DANGER



Nexto Series can operate with voltage up to 250 Vac. Special care must be taken during the installation, which should only be done by qualified technical personnel. Do not touch on the wiring field when in operation.

9. Manuals

For the correct application and use, the Nexto Series CPUs NX3003 User Manual - MU214605 should be consulted.

For more technical details, configuration, installation and programming of the Nexto Series, see the table below. This table is just a guide to some relevant documents that may be useful when using, maintaining and programming Nexto Series controllers. The complete and updated table containing all Nexto Series documents can be found in the Nexto Series User Manual - MU214600.

Code	Description	Language
CE114000 CT114000	Nexto Series – Technical Characteristics Série Nexto – Características Técnicas	English Portuguese
CE114105 CT114105	NX3003 Technical Characteristics Características Técnicas NX3003	English Portuguese
CE114700 CT114700	Nexto Series Backplane Racks Technical Characteristic Características Técnicas dos Bastidores da Série Nexto	English Portuguese
CE114810 CT114810	Nexto Series Accessories for Backplane Rack Technical Characteristics Características Técnicas Acessórios para Bastidor Série Nexto	English Portuguese
MU214600 MU214000	Nexto Series User Manual Manual de Utilização Série Nexto	English Portuguese
MU214618 MU214106	NX3003 CPU User Manual Manual de Utilização UCP NX3003	English Portuguese
MU299609 MU299048	MasterTool IEC XE User Manual Manual de Utilização MasterTool IEC XE	English Portuguese
MP399609 MP399048	MasterTool IEC XE Programming Manual Manual de Programação MasterTool IEC XE	English Portuguese
MU214603	Nexto Series HART Manual	English
MU214606	MQTT User Manual	English
MU214609	OPC UA Server for Altus Controllers User Manual	English
MU214610	Advanced Control Functions User Manual	English
MU214621	Nexto Series PROFINET Manual	English
NAP151	Utilização do Tunneller OPC	Portuguese

Table 17: Related Documents