

1. Product Description

Nexto Series is a powerful and complete Programmable Logic Controller (PLC) Series with unique and innovative features. Due to its flexibility, smart design, enhanced diagnostics capabilities and modular architecture, Nexto is suitable for control systems ranging from medium to high-end large applications. Finally, its compact size, high density of points per module and superior performance, allow Nexto Series to be applied in small automation systems with high performance requirements, such as manufacturing applications and industrial machines.

The Series has a wide variety of CPUs, I/O and communication modules with features to fit requirements in different kinds of applications. The options available cover from standard automation systems, high-availability applications where redundancy is a major requirement, distributed applications to functional safety systems.

Nexto Series has a wide range of digital I/O modules which were designed to fit requirements in different kinds of applications providing high-density I/O modules. NX2020 offers 16 source type protected relay outputs for general purpose use. NX2020 uses two positions in the Nexto Series rack. In addition it has some exclusive features brought by Nexto Series like Electronic Tag on Display, Easy Plug System and One Touch Diag.



Its main features are:

- High density, with 16 outputs in a compact module
- Two isolated output groups
- Protection against power supply polarity inversion
- External power supply low voltage diagnostic
- Display for module diagnostics and output state indication
- Easy Plug System
- One Touch Diag
- Electronic Tag on Display

2. Ordering Information

2.1. Included Items

The product package contains the following items:

- NX2020 module
- Two 10-terminals connector with wire holder

2.2. Product Code

The following code should be used to purchase the product:

Code	Description
NX2020	16 DO Relay Module

Table 1: Product Code

3. Related Products

The following product must be purchased separately when necessary:

Code	Description
NX9402	10-terminal connector with cable guides

Table 2: Related Products

4. Innovative Features

Nexto Series brings to the user many innovations regarding utilization, supervision and system maintenance. These features were developed focusing a new concept in industrial automation.



Easy Plug System: Nexto Series has an exclusive method to plug and unplug I/O terminal blocks. The terminal blocks can be easily removed with a single movement and with no special tools. In order to plug the terminal block back to the module, the frontal cover assists the installation procedure, fitting the terminal block to the module.



One Touch Diag: One Touch Diag is an exclusive feature that Nexto Series brings to PLCs. With this new concept, the user can check diagnostic information of any module present in the system directly on CPU's graphic display with one single press in the diagnostic switch of the respective module. OTD is a powerful diagnostic tool that can be used offline (without supervisor or programmer), reducing maintenance and commissioning times.

ETD – Electronic Tag on Display: Another exclusive feature that Nexto Series brings to PLCs is the Electronic Tag on Display. This new functionality brings the process of checking the tag names of any I/O pin or module used in the system directly to the CPU's graphic display. Along with this information, the user can check the description, as well. This feature is extremely useful during maintenance and troubleshooting procedures.

DHW – Double Hardware Width: Nexto Series modules were designed to save space in user cabinets or machines. For this reason, Nexto Series delivers two different module widths: Double Width (two backplane rack slots are required) and Single Width (only one backplane rack slot is required). This concept allows the use of compact I/O modules with a high-density of I/O points along with complex modules, like CPUs, fieldbus masters and power supply modules.



iF Product Design Award 2012: Nexto Series was the winner of iF Product Design Award 2012 in industry + skilled trades group. This award is recognized internationally as a seal of quality and excellence, considered the Oscars of the design in Europe..

5. Product Features

5.1. General Features

	NX2020
Backplane rack occupation	2 sequential slots
Output type	Relay output NO type
Number of outputs	16
Drive capacity for resistive load	2 A @ 30 Vdc 2 A @ 250 Vac
Maximum drive capacity per output group	4 A
Minimum load	100 μ A
Expected lifetime	100000 operations for resistive loads
Maximum contact resistance	100 m Ω
Switching time	Up to 7 ms (on-to-off transition) Up to 12 ms (off-to-on transition)
Maximum switching frequency	1 Hz
Output state indication	Yes
One Touch Diag (OTD)	Yes
Electronic Tag on Display (ETD)	Yes
Status and diagnostic indication	Display, web pages and CPU's internal memory
Hot swap capability	Yes
Module protections	Yes, power supply polarity inversion protection, protection against surge voltages and against short circuit
Wire gauge	0,5 mm ² (20 AWG) to 1,5 mm ² (16 AWG)
Minimum wire temperature rating	75 °C
Wire material	Copper only
Isolation	
Output group to output group	1000 Vac / 1 minute
Output to logic	2500 Vac / 1 minute
Output to protective earth \oplus	2500 Vac / 1 minute
Logic to protective earth \oplus	1500 Vac / 1 minute
External power supply to outputs / common terminal	1500 Vac / 1 minute
External power supply to protective earth \oplus	1250 Vac / 1 minute
Current consumption from backplane rack power supply	230 mA
External power supply	19.2 to 30 Vdc
External power supply current	140 mA @ 24 Vdc
Maximum power dissipation	6 W
IP level	IP 20
Operating temperature	0 to 60 °C
Storage temperature	-25 to 75 °C
Operating and storage relative humidity	5% to 96%, non-condensing
Conformal coating	Yes
Module dimensions (W x H x D)	36.00 x 114.63 x 117.05 mm
Package dimensions (W x H x D)	44.00 x 122.00 x 147.00 mm

	NX2020
Weight	250 g
Weight with package	300 g

Table 3: General Features

Notes:

Output type: NX2020 provides 16 relay outputs. The first eight outputs (00 to 07) use the same common terminal (terminal 9 of the connector A) and the last eight outputs (10 to 17) use another common terminal (terminal 9 of the connector B). More information can be found at [Installation](#).

Switching time: The switching time is the sum of the module update time plus relay update time regarding the respective output. The maximum module update time is 2 ms. The maximum relay update time (on-off) is 5 ms and the maximum relay update time (off-on) is 10 ms.

Maximum drive capacity per output group: The sum of all loads of a given group must not exceed the defined Maximum drive capacity per output group.

External power supply: NX2020 requires an external power supply used to supply the module's relays. The external power supply must be connected to terminal 10 of the connector A and B. More information can be found at [Installation](#).

ATTENTION

If the external power supply is below the 19.2 V limit, the outputs go to a safe state. However, since the display only shows the outputs' logical state, its indication may not match the physical state of outputs.

Wire gauge: Independent of selected wire, crimp terminals respecting the length as described in Manual de Utilização Série Nexto - MU214000.

External power supply current: Power supply current is the maximum current that can be drained from the external power supply.

Switching frequency: The switching frequency is the maximum frequency that can be used in the NX2020's outputs.

Conformal coating: Conformal coating protects the electronic components inside the product from moisture, dust and other harsh elements to electronic circuits.

5.2. Standards and Certifications

Standards and Certifications	
IEC	61131-2: Industrial-process measurement and control - Programmable controllers - Part 2: Equipment requirements and tests
	DNV Type Approval – DNV-CG-0339 (TAA000013D)
CE	2014/30/EU (EMC) 2014/35/EU (LVD) 2011/65/EU and 2015/863/EU (ROHS)
UKCA	S.I. 2016 No. 1091 (EMC) S.I. 2016 No. 1101 (Safety) S.I. 2012 No. 3032 (ROHS)
EAC	TR 004/2011 (LVD) CU TR 020/2011 (EMC)

Table 4: Standards and Certifications

5.3. Compatibility with Other Products

The following table provides information regarding the compatibility of the module NX2020 and Nexto Series programming tool MasterTool IEC XE.

NX2020		Compatible Software Version
Version	Revision	MasterTool IEC XE
1.0.0.0	AA	1.22 or higher
1.0.1.1 or higher	AB or higher	1.29 or higher

Table 5: Compatibility with Other Products

Note:

Revision: If the software/firmware is upgraded in the field the product revision indicated on the label will no longer match the actual revision of the product.

5.4. Physical Dimensions

Dimensions in mm.

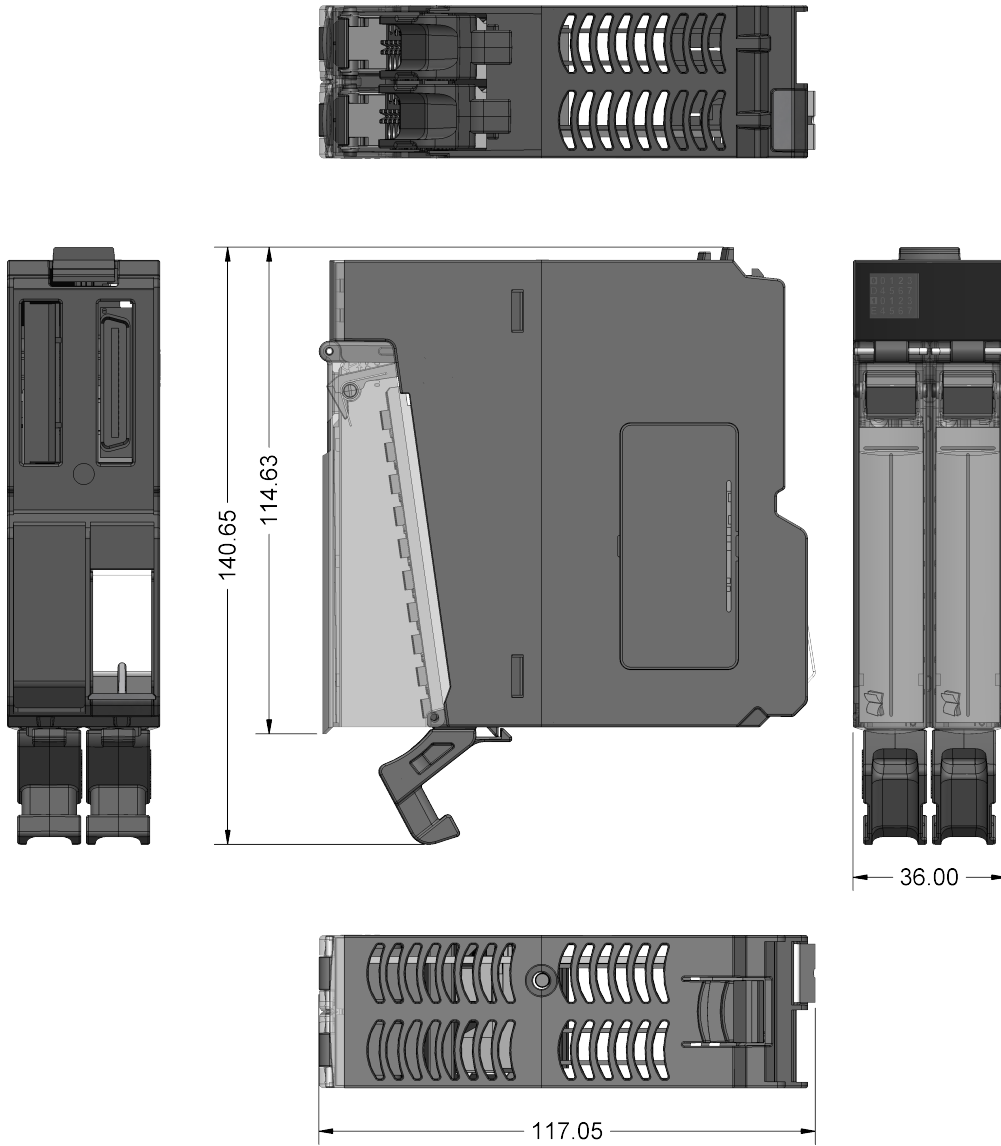

Figure 1: Physical Dimensions

6. Installation

For the correct installation of this product, it is necessary to use a rack (backplane rack) and it must be carried out according to the mechanical and electrical installation instructions that follow.

6.1. Product Identification

This product has some parts that must be observed before installation and use. The following figure identifies each of these parts.

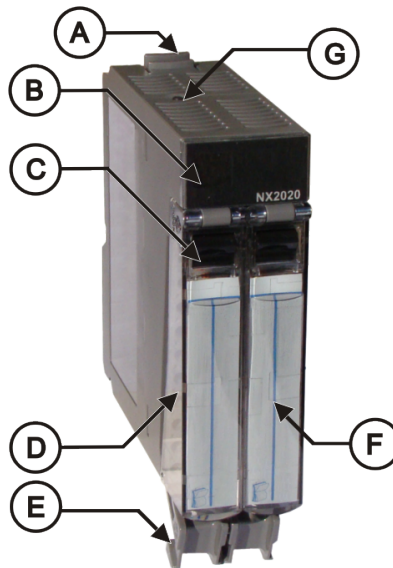

Figure 2: NX2020

- Ⓐ Fixing lock.
- Ⓑ Status and diagnostic display.
- Ⓒ Terminal block extraction lever.
- Ⓓ Front cover.
- Ⓔ 20 pin terminal block with wire holder.
- Ⓕ Label for module identification.
- Ⓖ Diagnostic switch.

The product has in its mechanics a label that identifies it and in it are presented some symbols whose meaning is described below:

⚠ Attention! Before using the equipment and installing, read the documentation.

⎓ Direct Current.

6.2. Electrical Installation

The figure below shows an example where each NX2020's output is connected to a different load. The outputs 00 to 07 are supplied by one power supply and the outputs 10 to 17 are supplied by a different one.

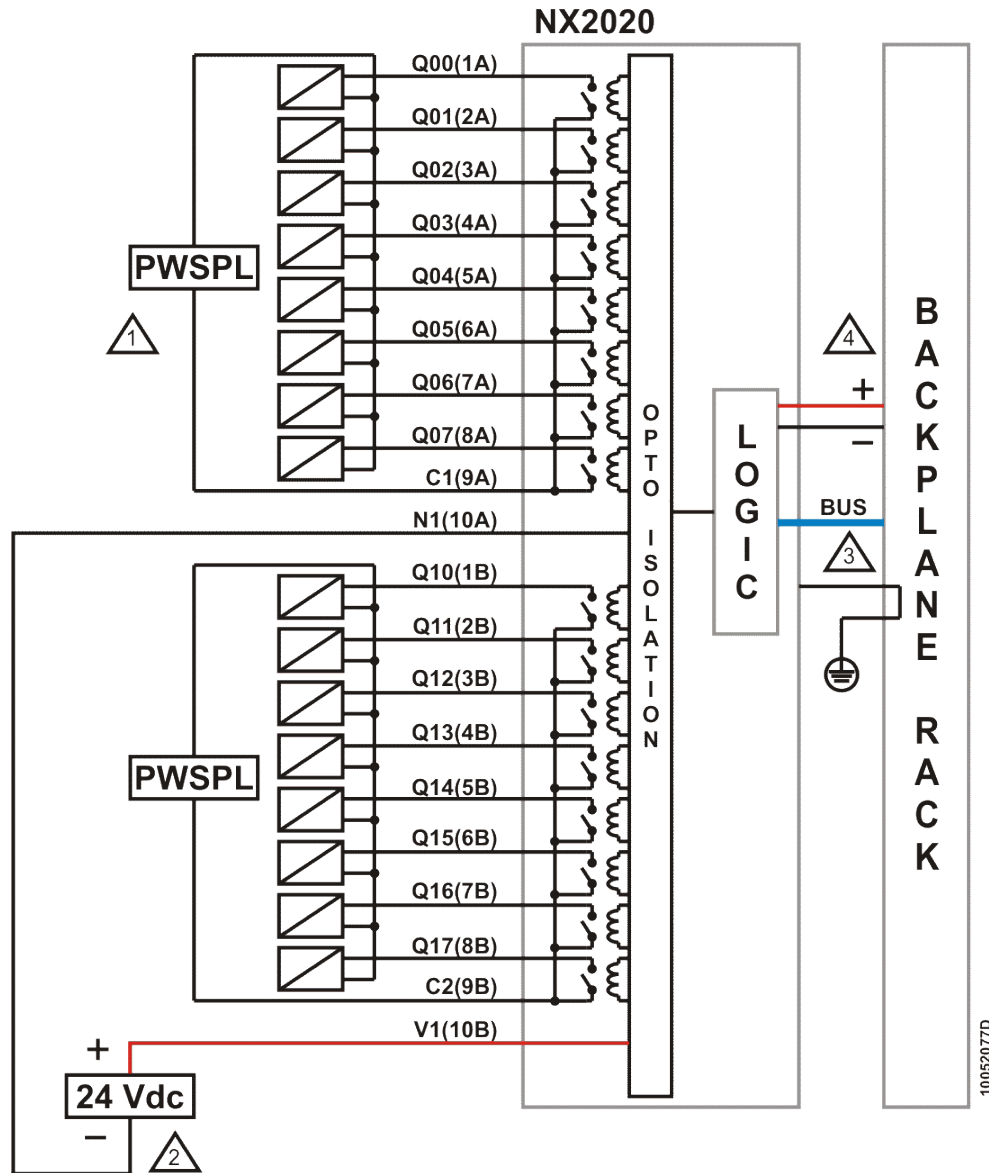

Figure 3: Electric Diagram

Diagram Notes:

- ⚠️ 1 Typical usage of source digital outputs.
- ⚠️ 2 External power supply to supply the outputs, V1 is connected to +24 Vdc and N1 is connected to 0 Vdc.
- ⚠️ 3 The module is grounded through the Nexto Series backplane rack.
- ⚠️ 4 The module power supply is derived from the connection to the backplane rack, not requiring external connections.
- ⚠️ Protective conductor terminal.

6.3. Connector Pinout

The following figure indicates the connector A and the connector B.

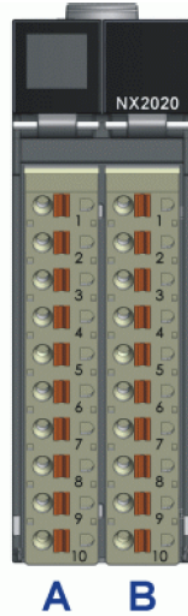

Figure 4: Connector Pinout

The following table shows the description of each connector terminal:

Terminal Number	Connector A Description	Connector B Description
1	Output 00	Output 10
2	Output 01	Output 11
3	Output 02	Output 12
4	Output 03	Output 13
5	Output 04	Output 14
6	Output 05	Output 15
7	Output 06	Output 16
8	Output 07	Output 17
9	Common for outputs 00 to 07	Common for outputs 10 to 17
10	(N1) 0 Vdc	(V1) +24 Vdc

Table 6: Connector Pinout

6.4. Protection Circuit

For further information, consult the "Lightning Protection" section of the Nexto Series User Manual - MU214600.

ATTENTION

Atmospheric discharges (thunders) may cause damages to the product although its protections. Additional protections should be used if the product's power comes from a power supply located outside the panel where it is installed because it could be vulnerable to this kind of discharges. If the field wiring of the output points is susceptible to this kind of discharge, surge suppressors should be used.

6.5. Mechanical and Electrical Assembly

The mechanical and electrical mounting and the connector insertion and removing for I/O modules are described at Nexto Series User Manual – MU214600.

ATTENTION

Products with broken warranty seal are not covered in warranty.

CAUTION



The device is sensitive to static electricity (ESD). Always touch in a metallic grounded object before handling it.

DANGER



Nexto Series can operate with voltage up to 250 Vac. Special care must be taken during the installation, which should only be done by qualified technical personnel. Do not touch on the wiring field when in operation.

7. Configuration

This module was developed to be used with Nexto Series products. All Nexto Series products are configured in MasterTool IEC XE. All configuration data of a given module can be accessed through a double click in it on the Graphical Editor.

7.1. Process Data

Process Data, when available, are the variables that are used to access and control the module. The list below describes all variables delivered by NX2020.

The process data of the module, when inserted in a PROFIBUS network, can be accessed through variables. The table below presents the variables organizational structure in the CPU memory.

Besides this data, NX2020 also provides a set of variables containing information related to diagnostics which are also described in this document.

Variable	Size	Process Data	Description	Type	Update
%QB(n)	BYTE	Digital Outputs - Byte 0	Output value of channel 00 to 07	Output (Read/Write)	Always
%QB(n+1)	BYTE	Digital Outputs - Byte 1	Output value of channel 10 to 17	Output (Read/Write)	Always

Table 7: Process Data

Note:

Update: The field Update indicates if, by default, the respective process data is updated by CPU and NX2020. When defined as Always, it means that the process data is always updated. When defined as Selectable, it means that the user can select if the respective process data will be updated or not. All these process data are exchanged between CPU and NX2020 through the bus. To improve CPU performance, it's recommended to update only the process data that will be used in the application.

7.2. Module Parameters

Name	Description	Standard value
%Q Start Address of Module Diagnostics Area	Defines the start address of the module diagnostics	-

Table 8: Module Parameters

8. Usage

8.1. General Purpose Output Write

NX2020 has two variables to control its outputs (Digital Outputs - Byte 0 and Digital Outputs - Byte 1). These variables have eight bits where each bit represents the logical state of each output channel. The relationship between each bit and its respective output can be found on the Bus I/O Mapping tab.

9. Maintenance

Altus recommends that all modules' connections should be checked and any dust or any kind of dirt in the module's enclosure should be removed at least every 6 months.

This module offers five important features to assist users during maintenance: Electronic Tag on Display, One Touch Diag, status and diagnostics indicators, web page with complete status and diagnostics list, and diagnostics mapped to internal memory.





9.1. Electronic Tag on Display and One Touch Diag

Electronic Tag on Display and One Touch Diag are important features that provide to the user the option to check the tag, description and diagnostics related to a given module directly on the CPU display.

Electronic Tag on Display and One Touch Diag are easy-to-use features. To check the tag and diagnostics of a given module, it's required only one short press (shorter than 1 s) on its diagnostic switch. After pressing once, CPU will start to scroll tag information and diagnostic information of the module. To access the respective module description just long press (longer than 1 s) the diagnostics switch of the respective module.

More information about Electronic Tag on Display and One Touch Diag can be found at User Manual of each respective CPU (listed at manual of Nexto Series - MU214600).

9.2. Status and Diagnostics Indicators

Nexto I/O modules have a display with the following symbols: D, E,  and  and numerical characters. The states of the symbols D, E,  and  are common for all Nexto Series I/O modules. These states can be consulted in the table below.

9.2.1. D and E States

D	E	Description	Cause	Solution	Priority
Off	Off	Display failure or module off	<ul style="list-style-type: none"> - Module disconnected; - External power supply failure; - Hardware failure. 	Check: <ul style="list-style-type: none"> - If the module is completely connected to the rack; - If the rack is powered by an external source; - If the module has external power. 	-
On	Off	Normal use	-	-	9 (Lower)
Blinking 1x	Off	Active diagnostics	There is at least one active diagnostic related to the module.	Check what the active diagnostic is. More information can be found at section Diagnostics Through Variables .	8
Blinking 2x	Off	No I/O data update	<ul style="list-style-type: none"> - CPU in STOP mode; - Head/Remote in non-ACTIVE state. 	Check: <ul style="list-style-type: none"> - If the CPU is in operation; - If the Fieldbus Master is in operation; - The integrity of the network between the MODBUS Client and the Head/Remote. 	7
Blinking 3x	Off	Reserved	-	-	6
Blinking 4x	Off	Non-fatal fault	Failure in some hardware or software component, which does not have impact on the basic functionality of the product.	Check the module's diagnostic information. If it is a hardware failure, have the part replaced. If it's software, contact Technical Support.	5
Off	Blinking 2x	Loss of bus master	Loss of communication between: <ul style="list-style-type: none"> - The module and the CPU; - The module and the Head/Remote; - The Head/Remote and the Field Network Master. 	Check: <ul style="list-style-type: none"> - If the module is completely connected to the rack; - If the CPU is in RUN mode; - If the Fieldbus Master is in operation; - Network integrity between PROFIBUS Master and Head/Remote. 	4
Off	Blinking 3x	Module without calibration	<ul style="list-style-type: none"> - The module is not calibrated; - There was an error with the calibration value. 	The module must return to the manufacturer.	3

D	E	Description	Cause	Solution	Priority
Off	Blinking 1x	Missing or parameterization error	The module isn't parameterized.	Check: - If the module parameterization is correct; - Network integrity between PROFIBUS Master and Head/Remote; - Network integrity between PROFINET Controller and Head/Remote.	2
Off	Blinking 4x	Fatal hardware fault	Hardware fault.	The module must return to the manufacturer.	1 (Higher)

Table 9: Status of Symbols D and E

Notes:

Field net master: There are different field net solutions, using different nomenclatures to refer to the net master. Examples: Profibus Master, MODBUS Client, PROFINET Controller, etc.

Module without calibration: Only valid for modules that have calibration, typically analog modules. Modules that do not have calibration will never show such an indication through the symbols D and E.

9.2.2. 0, 1 and Numerical Characters

The meaning of the numerical characters can be different for specific modules. In case of digital output modules, the numerical characters show the respective logic output state. When the numerical character is on, the respective output is also on and if the numerical character is off, the respective output is also off. The relationship between the output number and its respective numerical character can be found on the following figure.

The segments 0 and 1 are used to group the numerical characters used for the 16 outputs. The numerical characters that are placed at the right side of character 0 represent the outputs from 00 to 07 where character 0 is related to output 00 and character 7 is related to output 07. In the same way, the numerical characters that are placed at the right side of character 1 represent the outputs from 10 to 17 where character 0 is related to output 10 and character 7 is related to output 17. The figure below shows the relation between numerical characters and the respective outputs.

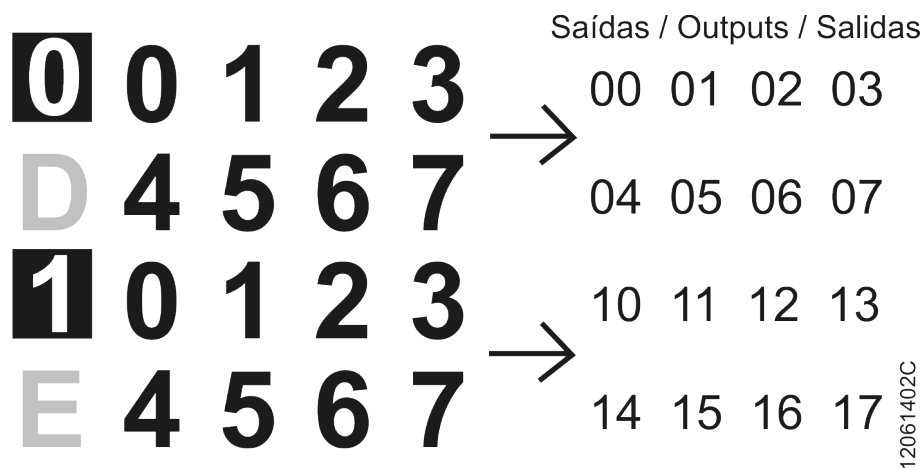

Figure 5: Display

9.3. Web Page with Complete Status and Diagnostics List

Another way to access diagnostics information on Nexto Series is via web pages. Nexto Series CPU's has an embedded web page server that provides all Nexto status and diagnostics information, which can be accessed using a simple browser.

More information about web page with complete status and diagnostics list can be found at User Manual of each respective CPU (listed at Nexto Series User Manual - MU214600).

9.4. Diagnostics Through Variables

All diagnostics in this module can be accessed through variables that can be handled by the user application or even forwarded to a supervisory system using a communication channel. There are two different ways to access diagnostics in the user application: using symbolic variables with AT directive or addressing memory. Altus recommends use symbolic variables for diagnostic accessing. The table below shows all available diagnostics for this module and their respective memory address, description, symbolic variable and string that will be shown on the CPU graphical display and web.

9.4.1. General Diagnostics

Direct Variable		Diagnostic Message	Symbolic Variable DG_NX2020.tGeneral.*	Description	PROFIBUS Message Code
Variable	Bit				
%QB(n)	0..7	Reserved			
%QB(n+1)	0	MODULE W/ DIAGNOSTIC	bActiveDiagnostics	TRUE – Module has active diagnostics	-
		NO DIAG		FALSE – Module doesn't have active diagnostics	
	1	MODULE W/ FATAL ERROR	bFatalError	TRUE – Fatal error	25
		-		FALSE – No fatal error	
	2	CONFIG. MISMATCH	bConfigMismatch	TRUE – Parameterization error	26
		-		FALSE – Parameterization ok	
	3	WATCHDOG ERROR	bWatchdogError	TRUE – Watchdog has been detected	27
		-		FALSE – No watchdog	
	4	OTD SWITCH ERROR	bOTDSwitchError	TRUE – Module has switch failure	28
		-		FALSE – Diagnostics switch ok	
	5..7	Reserved			

Table 10: General Diagnostics

9.4.2. Detailed Diagnostics

Direct Variable		Diagnostic Message	Symbolic Variable DG_NX2020.tDetailed.*	Description	PROFIBUS Message Code
Variable	Bit				
%QB(n+2)	0..7	Reserved			
%QB(n+3)	0	NO EXTERNAL SUPPLY	bNoExternalSupply	TRUE – No external power supply.	24
		-		FALSE – Power supply ok.	
	1..7	Reserved			

Table 11: Detailed Diagnostics

Notes:

Direct Representation Variable: "n" is the address defined in the field %Q Start Address of Module Diagnostics Area on the NX2020's configuration screen – Module Parameters tab in MasterTool IEC XE.

Symbolic Variable: Some symbolic variables serve to access diagnostics. These diagnostics are stored in the direct representation variable, then the AT directive is used to map the symbolic variables in the direct representation variable. The AT directive is a reserved word in the MasterTool IEC XE, that uses this directive to declare the diagnostics automatically on symbolic variables. All symbolic variables declared automatically can be found in the diagnostics object.

9.5. Hot Swap

This product supports hot swap. For further information about how to correctly perform a hot swap, consult Nexto Series User Manual - MU214600.

10. Manuals

For further technical details, configuration, installation and programming, the table below should be consulted.

The table below is only a guide of some relevant documents that can be useful during the use, maintenance, and programming of this product.

Code	Description	Language
CE114000	Nexto Series – Technical Characteristics	English
CT114000	Série Nexto – Características Técnicas	Portuguese
CS114000	Serie Nexto – Características Técnicas	Spanish
MU214600	Nexto Series User Manual	English
MU214000	Manual de Utilização Série Nexto	Portuguese
MU299609	MasterTool IEC XE User Manual	English
MU299048	Manual de Utilização MasterTool IEC XE	Portuguese
MP399609	MasterTool IEC XE Programming Manual	English
MP399048	Manual de Programação MasterTool IEC XE	Portuguese
MU214608	Nexto PROFIBUS-DP Head Utilization Manual	English
MU214108	Manual de Utilização da Cabeça PROFIBUS-DP Nexto	Portuguese

Table 12: Related Documents