

1. Product Description

Nexto Series is a powerful and complete Programmable Logic Controller (PLC) Series with unique and innovative features. Due to its flexibility, smart design, enhanced diagnostics capabilities and modular architecture, Nexto is suitable for control systems ranging from medium to high-end large applications. Finally, its compact size, high density of points per module and superior performance, allow Nexto Series to be applied in small automation systems with high performance requirements, such as manufacturing applications and industrial machines.

The Series has a wide variety of CPUs, I/O and communication modules with features to fit requirements in different kinds of applications. The options available cover from standard automation systems, high-availability applications where redundancy is a major requirement, distributed applications to functional safety systems.

The NX1001 is a digital input module designed to cover high I/O density requirements. NX1001 offers 16 isolated sink/-source inputs for general purpose use and it requires only one slot of Nexto Series Backplane Rack. Finally, Nexto Series has some innovative features for diagnosis and maintenance, such as Electronic Tag on Display, Easy Plug System and One Touch Diag.



Its main features are:

- High density, with 16 inputs in single width module
- Four independent input groups which can be used as sink or source inputs
- Isolated inputs
- Display for module diagnostics and input state indication
- Easy Plug System
- One Touch Diag
- Electronic Tag on Display

2. Ordering Information

2.1. Included Items

The product package contains the following items:

- NX1001 module
- 20-terminals connector with wire holder

2.2. Product Code

The following code should be used to purchase the product:

Code	Description
NX1001	24 Vdc 16 DI Module

Table 1: Product Code

3. Related Products

The following product must be purchased separately when necessary:

Code	Description
NX9403	20-terminal connector with cable guides

Table 2: Related Products

4. Innovative Features

Nexto Series brings to the user many innovations regarding utilization, supervision and system maintenance. These features were developed focusing a new concept in industrial automation.



Easy Plug System: Nexto Series has an exclusive method to plug and unplug I/O terminal blocks. The terminal blocks can be easily removed with a single movement and with no special tools. In order to plug the terminal block back to the module, the frontal cover assists the installation procedure, fitting the terminal block to the module.



One Touch Diag: One Touch Diag is an exclusive feature that Nexto Series brings to PLCs. With this new concept, the user can check diagnostic information of any module present in the system directly on CPU's graphic display with one single press in the diagnostic switch of the respective module. OTD is a powerful diagnostic tool that can be used offline (without supervisor or programmer), reducing maintenance and commissioning times.

ETD – Electronic Tag on Display: Another exclusive feature that Nexto Series brings to PLCs is the Electronic Tag on Display. This new functionality brings the process of checking the tag names of any I/O pin or module used in the system directly to the CPU's graphic display. Along with this information, the user can check the description, as well. This feature is extremely useful during maintenance and troubleshooting procedures.



iF Product Design Award 2012: Nexto Series was the winner of iF Product Design Award 2012 in industry + skilled trades group. This award is recognized internationally as a seal of quality and excellence, considered the Oscars of the design in Europe..

5. Product Features

5.1. General Features

	NX1001
Backplane rack occupation	1 slot
Input type	Sink or source type 1
Number of inputs	16
Input voltage	24 Vdc 15 to 30 Vdc for level logic 1 0 to 5 Vdc for level logic 0
Input impedance	4.18 kΩ - input 00 4.90 kΩ - inputs 01 to 07 and 10 to 17
Maximum input current	6 mA for 24 Vdc – input 00 5 mA for 24 Vdc – input 01 to 07 and 10 to 17
Input filter	100 μs – per hardware 2 to 255 ms – per software
Input update time	
Normal mode	1 ms
Counter mode	1.5 ms
Input state indication	Yes
Hardware external interruption	Yes
One Touch Diag (OTD)	Yes
Electronic Tag on Display (ETD)	Yes
Status and diagnostic indication	Display, web pages and CPU's internal memory
Hot swap capability	Yes
Wire gauge	0,5 mm ² (20 AWG)
Minimum wire temperature rating	75 °C
Wire material	Copper only
Isolation	
Input group to others input groups	1000 Vac / 1 minute
Inputs to logic	2500 Vac / 1 minute
Inputs to protective earth Ⓧ	2500 Vac / 1 minute
Logic to protective earth Ⓧ	1250 Vac / 1 minute
Current consumption from rack	160 mA
Maximum power dissipation	4 W
IP Level	IP 20
Operating temperature	0 to 60 °C
Storage temperature	-25 to 75 °C
Operating and storage relative humidity	5% a 96%, non-condensing
Conformal coating	Yes
Module dimensions (W x H x D)	18.00 x 114.62 x 117.46 mm
Package dimensions (W x H x D)	25.00 x 122.00 x 147.00 mm
Weight	200 g
Weight with package	250 g

Table 3: General Features

Notes:

Input Type: NX1001's inputs are divided in four input groups: 00 to 03, 04 to 07, 10 to 13 and 14 to 17. Each group can be used as source input as well as sink inputs independently of the type used in the other groups. To use an input group as source inputs, the respective common terminal must be connected to 24 Vdc. To use an input group as sink inputs, the respective common terminal must be connected to 0 Vdc. For more information please check the section [Installation](#).

Conformal Coating: Conformal coating protects the electronic components inside the product from moisture, dust and other harsh elements to electronic circuits.

Wire gauge: Crimp terminals for 0.5 mm² wire in each way respecting as described at Nexto Series User Manual - MU214600.

5.2. Standards and Certifications



Standards and Certifications	
IEC	61131-2: Industrial-process measurement and control - Programmable controllers - Part 2: Equipment requirements and tests
	DNV Type Approval – DNV-CG-0339 (TAA000013D)
CE	2014/30/EU (EMC) 2014/35/EU (LVD) 2011/65/EU and 2015/863/EU (ROHS)
UK CA	S.I. 2016 No. 1091 (EMC) S.I. 2016 No. 1101 (Safety) S.I. 2012 No. 3032 (ROHS)
	UL/cUL Listed – UL 61010-1 UL 61010-2-201 (file E473496)
EAC	TR 004/2011 (LVD) CU TR 020/2011 (EMC)

Table 4: Standards and Certifications

6. Installation

For the correct installation of this product, it is necessary to use a rack (backplane rack) and it must be carried out according to the mechanical and electrical installation instructions that follow.

6.1. Product Identification

This product has some parts that must be observed before installation and use. The following figure identifies each of these parts.

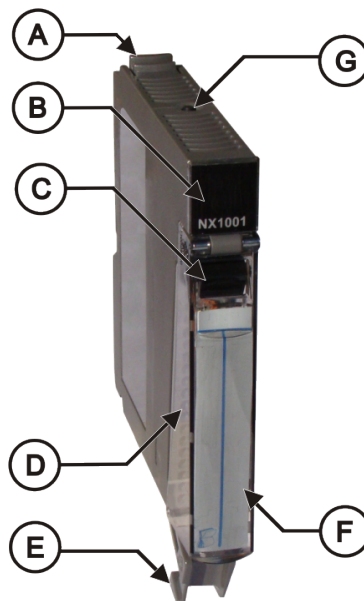

Figure 1: NX1001

- Ⓐ Fixing lock.
- Ⓑ Status and diagnostic display.
- Ⓒ Terminal block extraction lever.
- Ⓓ Front cover.
- Ⓔ 20 pin terminal block with wire holder.
- Ⓕ Label for module identification.
- Ⓖ Diagnostic switch.

The product has in its mechanics a label that identifies it and in it are presented some symbols whose meaning is described below:

⚠ Attention! Before using the equipment and installing, read the documentation.

⎓ Direct Current.

6.2. Electrical Installation

The figure below shows an example where NX1001 is used as sink or source inputs. The inputs 00 to 03 and 10 to 13 are used as sink inputs while inputs 04 to 07 and 14 to 17 are used as source inputs. Each input group is isolated.

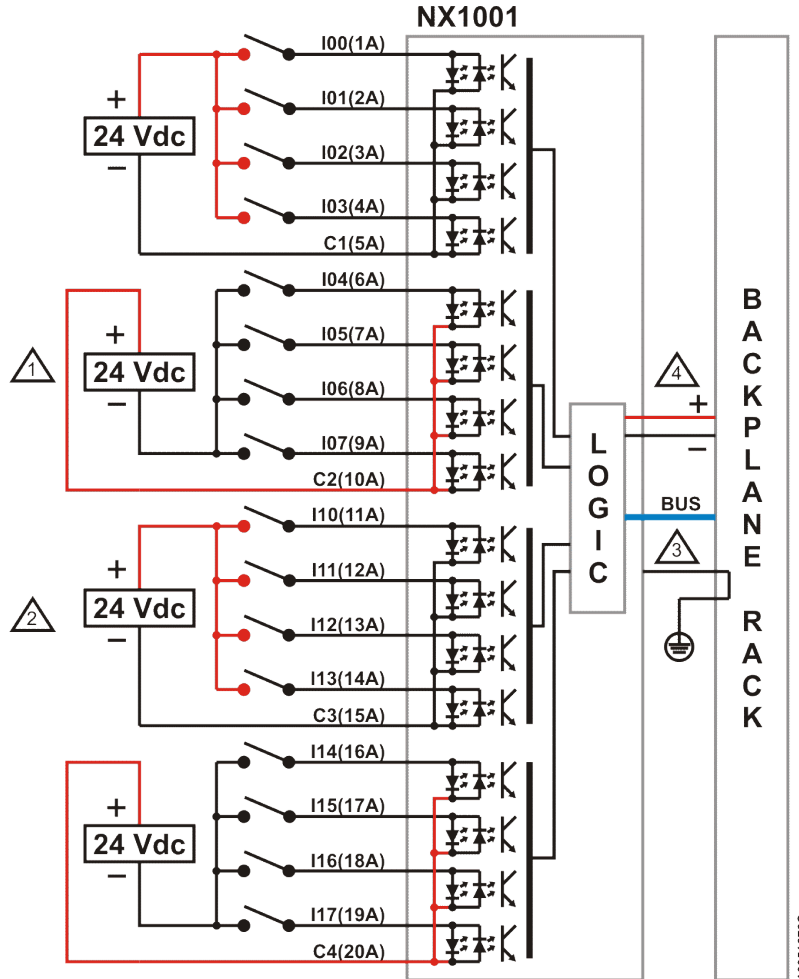

Figure 2: Electric Diagram

Diagram Notes:

- ① Typical usage of source digital inputs, C2 is the +24 Vdc common to input group I04 to I07.
- ② Typical usage of sink digital inputs, C3 is the 0 Vdc common to input group I10 to I13.
- ③ The module is grounded through the Nexto Series backplane racks.
- ④ The module power supply is derived from the connection to the backplane rack, not requiring external connections.
- ⊕ Protection earth terminal.

6.3. Connector Pinout

The following table shows the function of each connector terminal:

Terminal Number	Description
1	Input 00
2	Input 01
3	Input 02
4	Input 03
5	Comum for inputs 00 to 03
6	Input 04
7	Input 05
8	Input 06
9	Input 07
10	Comum for inputs 04 to 07
11	Input 10
12	Input 11
13	Input 12
14	Input 13
15	Comum for inputs 10 to 13
16	Input 14
17	Input 15
18	Input 16
19	Input 17
20	Comum for inputs 14 to 17

Table 5: Connector Pinout

6.4. Mechanical and Electrical Assembly

The mechanical and electrical mounting and the connector insertion and removing for single hardware width I/O modules are described at Nexto Series User Manual – MU214600.

ATTENTION

Products with broken warranty seal are not covered in warranty.

CAUTION



The device is sensitive to static electricity (ESD). Always touch in a metallic grounded object before handling it.

DANGER



Nexto Series can operate with voltage up to 250 Vac. Special care must be taken during the installation, which should only be done by qualified technical personnel. Do not touch on the wiring field when in operation.

6.5. Compatibility with Other Products

The following table provides information regarding the compatibility of the module NX1001 and Nexto Series programming tool MasterTool IEC XE.

NX1001			Software Version Compatible	
Version	Revision	Feature	MasterTool IEC XE	Nexto CPU's
1.0.0.0	AA	Mode 0	1.22 or higher	1.0.0.9 or higher
1.1.0.1 or higher	AB or higher	Mode 1, 2, 3, 4	1.29 or higher	
		Hardware External Event	1.31 or higher	1.2.2.1 or higher

Table 6: Compatibility with Other Products

Notes:

Mode 1, 2, 3, 4: The pulse capture, counters and period measurement features are only available from the software versions indicated in the table.

Hardware External Event: The hardware external event feature is available from the software versions indicated in the table. For a digital input to be used in events detection it should be a standard input. So, it should not have counters or other features linked to it. More information about Hardware External Event can be found at Nexto Series CPUs Utilization Manual – MU214605

Revision: If the software is upgraded in the field the product revision indicated on the label will no longer match the actual revision of the product.

6.6. Physical Dimensions

Dimensions in mm.

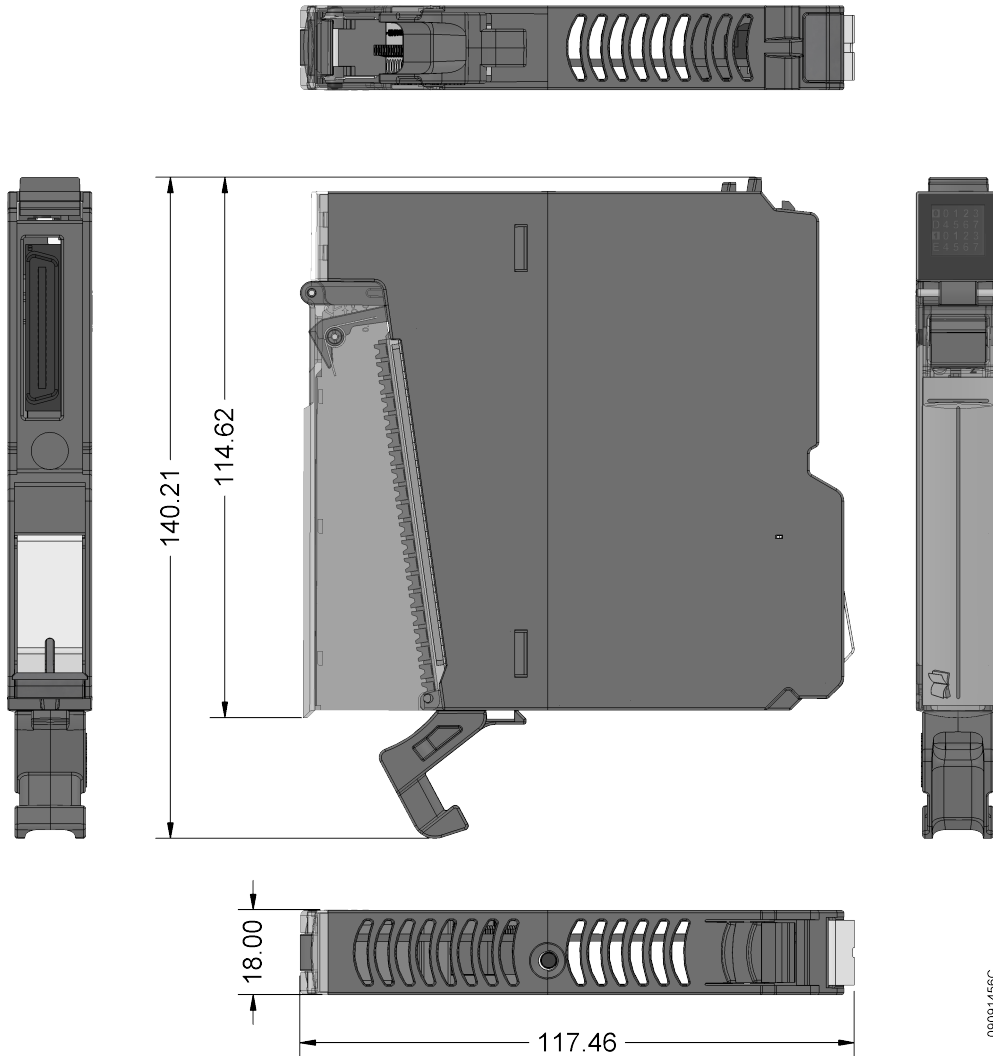

Figure 3: Physical Dimensions

7. Configuration

This module was developed to be used with Nexto Series products. All Nexto Series products are configured in MasterTool IEC XE. All configuration data of a given module can be accessed through a double click in it on the Graphical Editor.

7.1. Process Data

Process Data, when available, are the variables that are used to access and control the module. The list below describes all variables delivered by NX1001.

The process data of the module, when inserted in a PROFIBUS network, can be accessed through variables. The NX1001 module has two bytes to access the input data. The module NX1001 HSC is described in the table below that presents the variables organizational structure in the CPU memory.

Besides this data, NX1001 also provides a set of variables containing information related to diagnostics which are also described in this document.

Variable	Size	Process Data	Description	Type	Update
%QB(n)	BYTE	High Speed Counter Input 00 Command	Counter commands structure of input 00	Output (Write)	Selectable
%QB(n+1)	DWORD	High Speed Counter Input 00 Preset Value	Counter preset command of input 00	Output (Write)	Selectable
%QB(n+5)	BYTE	High Speed Counter Input 01 Command	Counter commands structure of input 01	Output (Write)	Selectable
%QB(n+6)	DWORD	High Speed Counter Input 01 Preset Value	Counter preset command of input 01	Output (Write)	Selectable
%QB(n+10)	BYTE	Pulse-Catch Reset – Byte 0	Reset command to recognize the pulse catch of inputs 00 to 07	Output (Write)	Selectable
%IB(n)	BYTE	Digital Inputs - Byte 0	Input value of channel 00 to 07	Input (Read)	Always
%IB(n+1)	BYTE	Digital Inputs - Byte 1	Input value of channel 10 to 17	Input (Read)	Always
%IB(n+2)	BYTE	High Speed Counter Input 00 Status	Counter commands status of input 00	Input (Read)	Selectable
%IB(n+3)	DWORD	High Speed Counter Input 00 Current Value	Counter value of input 00	Input (Read)	Selectable
%IB(n+7)	BYTE	High Speed Counter Input 01 Status	Counter commands status of input 01	Input (Read)	Selectable
%IB(n+8)	DWORD	High Speed Counter Input 01 Current Value	Counter value of input 01	Input (Read)	Selectable
%IB(n+12)	DWORD	Input 02 Period	Period measurement value of input 02	Input (Read)	Selectable

Table 7: Process Data

Note:

Update: The field *Update* indicates if the respective process data is updated by CPU and NX1001. When defined as *Always*, it means that the process data is always updated. When defined as *Selectable*, means that the user can select if the respective process data will be updated or not. All these process data are exchanged between CPU and NX1001 through the bus, to improve CPU performance, it's recommended to update only the process data that will be used in the application.

7.2. Module Parameters

Name	Description	Options	Standard value
Operating Mode	Sets special features configuration mode	Mode 0 Mode 1 Mode 2 Mode 3 Mode 4	Mode 0
Input Filter Enable Mask	Enables or disables input filter feature per channel	False True	False
Input Filter Time Constant	Sets input filter time constant (ms)	2 - 255	7
Pulse-Catch Enable Mask	Enables or disables pulse catcher	False True	False
Pulse-Catch Elongation Time	Sets the Elongation Time of the pulse catch	0 - 255	50
Period Measurement Enable Mask	Enables or disables period measurement (available only to input 02)	False True	False
%Q Start Address of Module Diagnostics Area	Defines the start address of the module diagnostics	-	-

Table 8: Module Parameters

Notes:

Operating Mode: For further information, the [Operating Modes](#) section should be consulted.

Input Filter Enable Mask: The field can be selected by the user to enable the input filter feature in a specific channel. If the input filter is enabled in a channel, the module will reject pulses smaller than the time configured in the *Input Filter Time Constant*.

Input Filter Time Constant: The field determines the time to apply in the filter and this parameter can be set from 2 to 255 ms. If enabled some different operation mode than Mode 0, this parameter is ignored for inputs related to the selected operating mode, the remaining inputs must have the same behavior of Mode 0.

Elongation Time of Pulse Catch: This field determines the time that the pulse detected by the input module will remain active, so it is suggested that the set value in this field is always greater than the cycle time of application. The range configuration of this parameter is 0 to 255 ms.

7.2.1. Operating Modes

NX1001 provides five operation modes, where each one has some functionality features in common and also specific features. The table below describes the available features in each operation mode:

Operating Mode	Description
Mode 0	Input 00 to 07 and 10 to 17: Standard digital input
Mode 1	Input 00 to 07: Pulse catch Input 00 to 07 and 10 to 17: Standard digital input (only in disabled pulse catch inputs)
Mode 2	Input 00: Counter 1, count direction defined by software Input 01: Standard digital input Input 02: Period measurement Input 03 to 07 and 10 to 17: Standard digital input

Operating Mode	Description
Mode 3	Input 00: Counter 1, count direction defined by Input 01 Input 01: Count direction control of Counter 1 Input 02: Period measurement Input 03 to 07 and 10 to 17: Standard digital input
Mode 4	Input 00: Counter 1, count direction defined by software Input 01: Counter 2, count direction defined by software Input 02: Period measurement Input 03 to 07 and 10 to 17: Standard digital input

Table 9: Operating Modes

7.2.2. Mode 1: Pulse Catch

Pulse catch functionality can be configured when you select the operation mode 1, as can be seen in the table above. This feature is used to detect fast pulses, which cannot be identified during a standard scan of the application, and increase them for such a scan can detect.

The capture of the pulse can be enabled individually for each digital input via Pulse-Catch Enable Mask parameter. The inputs that are not used as pulse catch can be used as standard digital input.

The behavior of the pulse catch is associated with the identification of pulses with not less than 1 ms width, generated by field signal in the respective input enabled. When this is identified, the module indicates through the Digital Inputs - Byte 0 variables setting the bit corresponding to input that is with this feature enabled. This bit will remain on for the time configured in the Pulse-Catch Elongation Time parameter. We recommend configuring in this parameter a time greater than the Interval Time of the Main Task; otherwise the standard scan may not detect this.

The command Pulse-Catch Reset has priority over the field signal, i.e., when this command is active for the corresponding input, the pulses generated by the field signal are ignored.

In order to exemplify the behavior described above, the figures below indicate the State of the field signal, Pulse-Catch Reset command and the result of this functionality in Digital Inputs - Byte 0 variables.

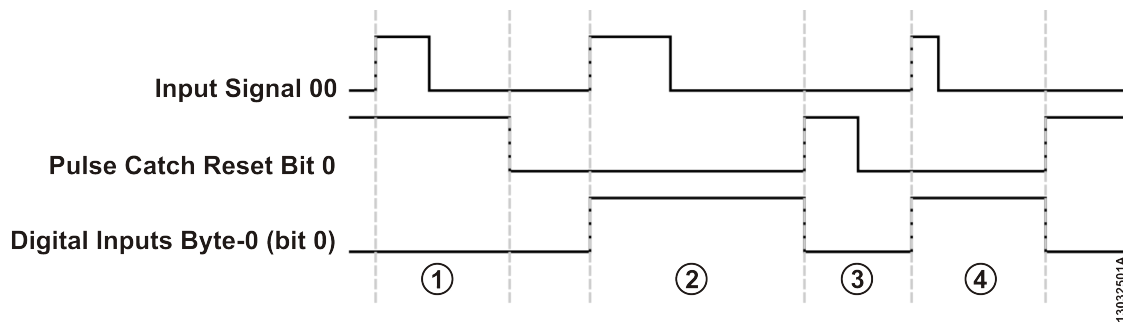

Figure 4: Pulse Catch

Notes :

1. Pulse generated by the field signal more than 1 ms at the input 00 but with the command Pulse-Catch Reset bit 0 on, in this case the user will not identify any change in the Digital Inputs - Byte 0 bit 0 variable.
2. Pulse generated by field signal more than 1 ms at the input 00 with Pulse-Catch Reset bit 0 command off; in this case the module sets the bit 0 of the Digital Inputs - Byte 0 variable, keeping it in TRUE until the reset command. In this case the application scan interval identifies the pulse that was captured by this feature.
3. Displays the reset signal turning off the bit 0 of the Digital Inputs - Byte 0 variable.
4. This case presents a pulse equal to 1 ms in field signal, which is identified by the module. In this way the bit 0 of the Digital Inputs - Byte 0 variable remains on until the reset command.

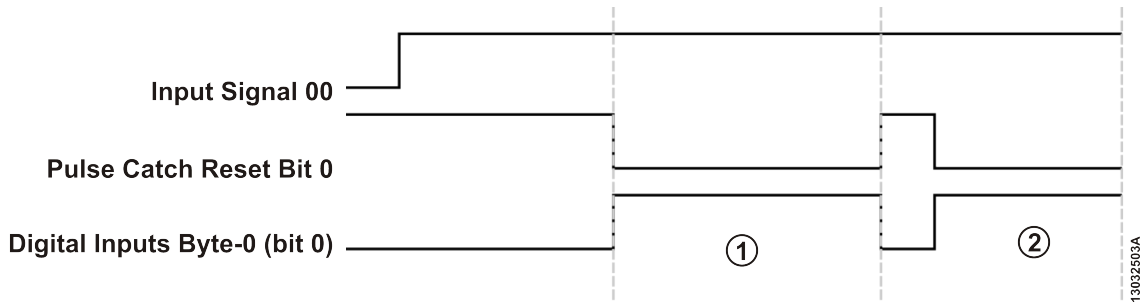

Figure 5: Pulse Catch

Notes:

1 and 2: If the field signal does not generate pulses and stay always on, the signal from the Digital Inputs - Byte 0 variable will be switched on whenever there is a transition from the reset command. In this situation, the signal of Digital Inputs - Byte 0 variable may only be turned on when the Pulse-Catch Reset command is off.

7.2.3. Mode 2: Counter

The counter in operation mode 2 is able to register Input 00 count and set the count direction by up and down functions via software command, which is available in bit 0 of the High Speed Counter Input 00 Command, called Direction. The count value can be read through the variable High Speed Counter Input 00 Current Value which can assume the values defined in the count presented on the table of characteristics of the mode 2.

To run a stop counting, using the command Stop Counter in the variable command. Other commands such as Preset, Reset and Hold counter can also be performed. The logical state of any command activation is logic level 1, and these will be accepted only if the counter is running or stopped mode (STOP).

If the Reset and Preset commands are sent simultaneously to the module, the Reset command is performed. The same applies to the Stop and Hold commands, but in this case the Stop command is performed.

The status bit Direction – in Run and Stop modes - informs the counting direction. But in Hold mode, it indicates the last valid configuration.

The Reset and Preset status indicate when the command was successfully held. Their value resets when command bit goes to zero.

In case of counter overflow, that is, when the value of the count reaches its maximum value the count will automatically assume the minimum value.

Counter Mode 2	
Count input	Input 00
Count range	-2,147,483,648 to +2,147,483,647
Count direction control	By software
Maximum frequency of the count input (fc)	20 kHz
Minimum time of count direction setting	10 ms
Update time	2 ms
Count input detection edge	Fall, active on logical level 0

Table 10: Counter Mode 2

ATTENTION

It is recommended to use a duty cycle of 50% for counter inputs.

Process Data	Bit	Command	Description
High Speed Counter Input 00 Command	0	Direction	Sets the direction of the count: FALSE – count up TRUE – countdown
	1	Stop Counter	Runs the counter stop FALSE – running conter TRUE – stops the count
	2	Hold Counter	Freezes the count value FALSE – running conter TRUE – freezes value in the variable HSC Input 00 Current Value, but continues to count
	3	Reset Counter	TRUE – returns the count to zero
	4	Preset Counter	TRUE – loads the counter with the value of HSC Input 00 Preset Value
	5..7	Reserved	Reserved
	High Speed Counter Input 00 Preset Value	DINT	Contains the value to be loaded into the counter
High Speed Counter Input 00 Status	0	Direction	Indicates the direction of the count
	1	Stop Counter	Indicates whether the counter is stopped
	2	Hold Counter	Indicates whether the value of the counter was frozen
	3	Reset Counter	Indicates that the count returned to zero
	4	Preset Counter	Indicates that the value of HSC Input 00 Preset Value was loaded into the counter.
	5..7	Reserved	Reserved
High Speed Counter Input 00 Current Value	DINT	Contains the value of the count	

Table 11: Process Data of Mode 2 Counter

7.2.4. Modo 3: Counter

The count mode available in operating mode 3 has the same functionality of the mode 2 with some particularities: the count direction is not configured by software but rather through the logical state of the input 01. The option “count up” is defined by the logical state 0 and countdown by logical state 1. The other commands have the same operating form of mode 2. The table below presents the general characteristics and limits in this mode.

	Counter Mode 3
Count input	Input 00
Control input	Input 01
Count range	-2,147,483,648 to +2,147,483,647
Maximum frequency of the count input (fc)	20 kHz
Maximum frequency of the control input	2 kHz
Minimum time control input configuration	100 μs
Update time	2 ms
Count input detection edge	Fall, active on logical level 0
Control input detection edge	Rise – countdown Fall – count up

Table 12: Counter Mode 3

The chart below shows the behavior of the counter input 00 in relation to input 01 which serves to set the count direction.

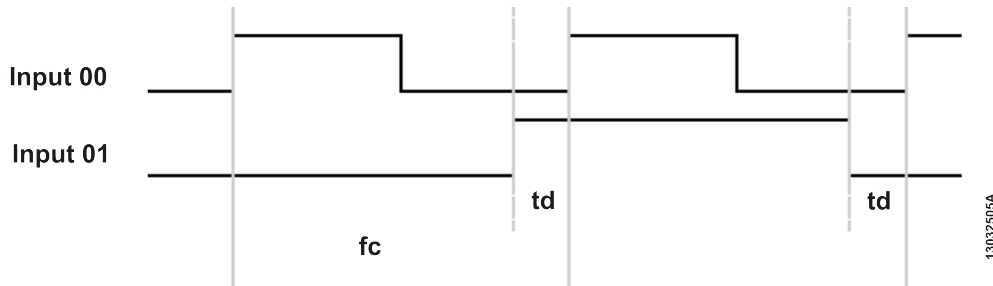

Figure 6: Counter

Notes:

fc: Sets the maximum frequency of the count signal.

td: Sets the minimum time for count signal identification, and the minimum value is 100 μ s.

7.2.5. Mode 4: Counter

The count mode available in operating mode 4 has two counters: fast count input (Input 00 counter) and count input (Input 01 counter). The commands operate in the same manner as in mode 2, whose count direction is determined by software. The table below presents the general characteristics and limits in this mode.

	Counter Mode 4
Fast count input	Input 00
Count input	Input 01
Count range	-2,147,483,648 to +2,147,483,647
Maximum frequency of the fast count input	20 kHz
Maximum frequency of the count input	2 kHz
Minimum time count direction configuration	10 ms
Update time	2 ms
Fast count input detection edge	Fall, active on logical level 0
Count input detection edge	Fall, active on logical level 0

Table 13: Counter Mode 4

Note:

Update Time: Is the time required to update a new measurement.

7.2.6. Period Measurement in Modes 2, 3 and 4

The period measurement mode is available in operating modes 2, 3 and 4, at the input 02. General information and limits are presented in the table below.

	Period measurement
Measurement input	Input 02
Minimum period / Maximum frequency	200 μ s / 5 kHz
Maximum period / Minimum frequency	1 s / 1 Hz
Sensitivity	1 μ s
Precision	< 2% of the measured value

	Period measurement
Pulses for measuring	4 pulses
Update time	2 ms
Detection edge	Fall, active on logical level 0

Table 14: Period Measurement

Notes:

Pulses for Measuring: For period measuring are necessary only four pulses on rise edge of the signal.

Update Time: Is the time required to update a new measurement.

ATTENTION

If there is no signal in input 02, Input 02 Period will show the last valid value for 2 s and after will show zero, if there is a signal with frequency out of range specified above, the value shown in Input 02 Period is zero.

8. Usage

8.1. General Purpose Input Read

NX1001 has two variables to access its inputs (Digital Inputs - Byte 0 and Digital Inputs - Byte 1). Both variables have eight bits where each bit represents the physical input state of a given input channel. The relationship between each bit and its respective input can be found on the Bus I/O Mapping tab.

9. Maintenance

Altus recommends that all modules' connections should be checked and any dust or any kind of dirt in the module's enclosure should be removed at least every 6 months.

This module offers five important features to assist users during maintenance: Electronic Tag on Display, One Touch Diag, status and diagnostics indicators, web page with complete status and diagnostics list, and diagnostics mapped to internal memory.





9.1. Electronic Tag on Display and One Touch Diag

Electronic Tag on Display and One Touch Diag are important features that provide to the user the option to check the tag, description and diagnostics related to a given module directly on the CPU display.

Electronic Tag on Display and One Touch Diag are easy-to-use features. To check the tag and diagnostics of a given module, it's required only one short press (shorter than 1 s) on its diagnostic switch. After pressing once, CPU will start to scroll tag information and diagnostic information of the module. To access the respective module description just long press (longer than 1 s) the diagnostics switch of the respective module.

More information about Electronic Tag on Display and One Touch Diag can be found at User Manual of each respective CPU (listed at manual of Nexto Series - MU214600).

9.2. Status and Diagnostics Indicators

Nexto I/O modules have a display with the following symbols: D, E,  and  and numerical characters. The states of the symbols D, E,  and  are common for all Nexto Series I/O modules. These states can be consulted in the table below.

9.2.1. D and E States

D	E	Description	Cause	Solution	Priority
Off	Off	Display failure or module off	<ul style="list-style-type: none"> - Module disconnected; - External power supply failure; - Hardware failure. 	Check: <ul style="list-style-type: none"> - If the module is completely connected to the rack; - If the rack is powered by an external source; - If the module has external power. 	-
On	Off	Normal use	-	-	9 (Lower)
Blinking 1x	Off	Active diagnostics	There is at least one active diagnostic related to the module.	Check what the active diagnostic is. More information can be found at section Diagnostics Through Variables .	8
Blinking 2x	Off	No I/O data update	<ul style="list-style-type: none"> - CPU in STOP mode; - Head/Remote in non-ACTIVE state. 	Check: <ul style="list-style-type: none"> - If the CPU is in operation; - If the Fieldbus Master is in operation; - The integrity of the network between the MODBUS Client and the Head/Remote. 	7
Blinking 3x	Off	Reserved	-	-	6
Blinking 4x	Off	Non-fatal fault	Failure in some hardware or software component, which does not have impact on the basic functionality of the product.	Check the module's diagnostic information. If it is a hardware failure, have the part replaced. If it's software, contact Technical Support.	5
Off	Blinking 2x	Loss of bus master	Loss of communication between: <ul style="list-style-type: none"> - The module and the CPU; - The module and the Head/Remote; - The Head/Remote and the Field Network Master. 	Check: <ul style="list-style-type: none"> - If the module is completely connected to the rack; - If the CPU is in RUN mode; - If the Fieldbus Master is in operation; - Network integrity between PROFIBUS Master and Head/Remote. 	4
Off	Blinking 3x	Module without calibration	<ul style="list-style-type: none"> - The module is not calibrated; - There was an error with the calibration value. 	The module must return to the manufacturer.	3

D	E	Description	Cause	Solution	Priority
Off	Blinking 1x	Missing or parameterization error	The module isn't parameterized.	Check: - If the module parameterization is correct; - Network integrity between PROFIBUS Master and Head/Remote; - Network integrity between PROFINET Controller and Head/Remote.	2
Off	Blinking 4x	Fatal hardware fault	Hardware fault.	The module must return to the manufacturer.	1 (Higher)

Table 15: Status of Symbols D and E

Notes:

Field net master: There are different field net solutions, using different nomenclatures to refer to the net master. Examples: Profibus Master, MODBUS Client, PROFINET Controller, etc.

Module without calibration: Only valid for modules that have calibration, typically analog modules. Modules that do not have calibration will never show such an indication through the symbols D and E.

9.2.2. 0, 1 and Numerical Characters

The meaning of the numerical characters can be different for specific modules. In case of digital input modules, the numerical characters represent its physical state as well. When the numerical character is on, the respective input is also on, and if the numerical character is off, the respective input is also off. The relationship between the input number and its respective numerical character can be found on the following figure.

The segments 0 and 1 are used to group the numerical characters used for the 16 inputs. The numerical characters that are placed at the right side of character 0 represent the inputs from 00 to 07, where character 0 is related to input 00 and character 7 is related to input 07. In the same way the numerical characters that are placed at the right side of character 1 represent the inputs from 10 to 17, where character 0 is related to input 10 and the character 7 is related to input 17. The figure below shows the relation between numerical characters and the respective inputs.

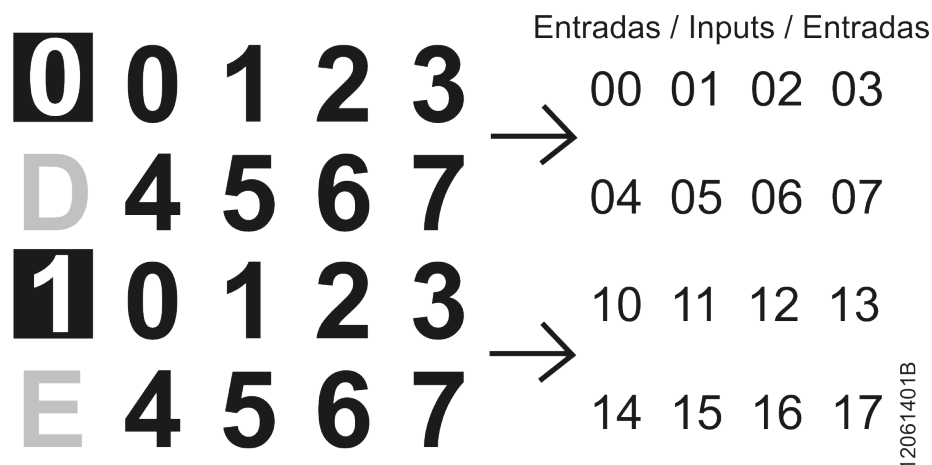

Figure 7: Display

9.3. Web Page with Complete Status and Diagnostics List

Another way to access diagnostics information on Nexto Series is via web pages. Nexto Series CPU's has an embedded web page server that provides all Nexto status and diagnostics information, which can be accessed using a simple browser.

More information about web page with complete status and diagnostics list can be found at User Manual of each respective CPU (listed at Nexto Series User Manual - MU214600).

9.4. Diagnostics Through Variables

All diagnostics in this module can be accessed through variables that can be handled by the user application or even forwarded to a supervisory system using a communication channel. There are two different ways to access diagnostics in the user application: using symbolic variables with AT directive or addressing memory. Altus recommends use symbolic variables for diagnostic accessing. The table below shows all available diagnostics for this module and their respective memory address, description, symbolic variable and string that will be shown on the CPU graphical display and web.

9.4.1. General Diagnostics

Direct Variable		Diagnostic Message	Symbolic Variable DG_NX1001.tGeneral.*	Description	PROFIBUS Message Code
Variable	Bit				
%QB(n)	0..7	Reserved			
%QB(n+1)	0	MODULE W/ DIAGNOSTICS	bActiveDiagnostics	TRUE – Module has active diagnostics	-
		NO DIAG		FALSE – Module doesn't have active diagnostic	
	1	MODULE W/ FATAL ERROR	bFatalError	TRUE – Fatal error	25
		-		FALSE – No fatal error	
	2	CONFIG. MISMATCH	bConfigMismatch	TRUE – Parameterization error	26
		-		FALSE – Parameterization ok	
	3	WATCHDOG ERROR	bWatchdogError	TRUE – Watchdog has been detected	27
		-		FALSE – No watchdog	
	4	OTD SWITCH ERROR	bOTDSwitchError	TRUE – Module has diag- nostic switch failure	28
		-		FALSE – Diagnostic switch ok	
	5..7	Reserved			

Table 16: General Diagnostics

Notes:

Direct Representation Variable:"n" is the address defined in the field %Q Start Address of Module Diagnostics Area on the NX1001's configuration screen – Module Parameters tab in the MasterTool IEC XE.

Symbolic Variable:Some symbolic variables serve to access diagnostics. These diagnostics are stored in the direct representation variable, then the AT directive is used to map the symbolic variables in the direct representation variable. The directive AT is a reserved word in the MasterTool IEC XE, that uses this directive to declare the diagnostics automatically on a symbolic variables. All symbolic variables declared automatically can be found in the Diagnostics object.

9.5. Hot Swap

This product supports hot swap. For further information about how to correctly perform a hot swap, consult Nexto Series User Manual - MU214600.

10. Manuals

For further technical details, configuration, installation and programming, the table below should be consulted.

The table below is only a guide of some relevant documents that can be useful during the use, maintenance, and programming of this product.

Code	Description	Language
CE114000	Nexto Series – Technical Characteristics	English
CT114000	Série Nexto – Características Técnicas	Portuguese
CS114000	Serie Nexto – Características Técnicas	Spanish
MU214600	Nexto Series User Manual	English
MU214000	Manual de Utilização Série Nexto	Portuguese
MU299609	MasterTool IEC XE User Manual	English
MU299048	Manual de Utilização MasterTool IEC XE	Portuguese
MP399609	MasterTool IEC XE Programming Manual	English
MP399048	Manual de Programação MasterTool IEC XE	Portuguese
MU214608	Nexto PROFIBUS-DP Head Utilization Manual	English
MU214108	Manual de Utilização da Cabeça PROFIBUS-DP Nexto	Portuguese

Table 17: Related Documents