

## 1. Product Description

Nexto Series is a powerful and complete Programmable Logic Controller (PLC) Series with unique and innovative features. Due to its flexibility, smart design, enhanced diagnostics capabilities and modular architecture, Nexto is suitable for control systems ranging from medium to high-end large applications. Finally, its compact size, high density of points per module and superior performance, allow Nexto Series to be applied in small automation systems with high performance requirements, such as manufacturing applications and industrial machines.

In this context, Nexto Jet is a selection of I/O modules that uses the existing CPUs and modules from Nexto Series to provide the best solution for applications in verticals like infrastructure, building, water, wastewater, food, machines and several OEM projects. Nexto Jet is ideal for systems with no hot-swapping and conformal coating requirements.

Finally, the module NJ1001 is a module that offers 16 isolated inputs of source/sink type for general use and it is a module that uses one rack position.



Its main features are:

- High density, with 16 inputs in single width module
- Four independent input groups which can be used as sink or source inputs
- Isolated inputs
- Display for module diagnostics and input state indication
- Easy Plug System

### ATTENTION

Starting from product revision AI, it was included the connector frontal cover (which was previously exclusive of NX models), thus adding the Easy Plug System feature to this product.

## 2. Ordering Information

### 2.1. Included Items

The product package contains the following items:

- NJ1001 module
- 20-terminals connector with wire holder

### 2.2. Product Code

The following code should be used to purchase the product:

Code	Description
NJ1001	24 Vdc 16 DI Module

Table 1: Product Code

### 3. Related Products

The following product must be purchased separately when necessary:

Code	Description
NX9403	20-terminal connector with cable guides

Table 2: Related Products

### 4. Innovative Features

Nexto Series brings to the user many innovations regarding utilization, supervision and system maintenance. These features were developed focusing a new concept in industrial automation.



**Easy Plug System:** Nexto Series has an exclusive method to plug and unplug I/O terminal blocks. The terminal blocks can be easily removed with a single movement and with no special tools. In order to plug the terminal block back to the module, the frontal cover assists the installation procedure, fitting the terminal block to the module.

### 5. Product Features

#### 5.1. General Features

	NJ1001
Backplane rack occupation	1 slot
Input type	Sink or source type 1
Number of inputs	16
Input voltage	24 Vdc 15 to 30 Vdc for level logic 1 0 to 5 Vdc for level logic 0
Input impedance	4.95 kΩ
Maximum input current	6.2 mA @ 30 Vdc
Input filter	2 to 255 ms – per software
Transaction time	90 μs - transaction off to on @ 30 Vdc 110 μs - transaction on to off @ 30 Vdc
Input update time	1 ms
Input state indication	Yes
One Touch Diag (OTD)	No
Electronic Tag on Display (ETD)	No
Status and diagnostic indication	Display, web pages and CPU's internal memory
Hot swap capability	No
Wire gauge	0,5 mm <sup>2</sup> (20 AWG)
Minimum wire temperature rating	75 °C
Wire material	Copper only
Isolation	
Input group to others input groups	1000 Vac / 1 minute
Inputs to logic	2500 Vac / 1 minute

	NJ1001
Inputs to protective earth $\oplus$	2500 Vac / 1 minute
Logic to protective earth $\oplus$	1500 Vac / 1 minute
Current consumption from rack	160 mA
Maximum power dissipation	3.8 W
IP Level	IP 20
Operating temperature	0 to 60 °C
Storage temperature	-25 to 75 °C
Operating and storage relative humidity	5% to 96%, non-condensing
Module dimensions (W x H x D)	18.00 x 114.62 x 117.46 mm
Package dimensions (W x H x D)	25.00 x 122.00 x 147.00 mm
Weight	200 g
Weight with package	250 g

Table 3: General Features

**Notes:**

**Input Type:** NJ1001's inputs are divided in four input groups: 00 to 03, 04 to 07, 10 to 13 and 14 to 17. Each group can be used as source input as well as sink inputs independently of the type used in the other groups. To use an input group as source inputs, the respective common terminal must be connected to 24 Vdc. To use an input group as sink inputs, the respective common terminal must be connected to 0 Vdc. For more information please check the section [Installation](#).

**Input filter:** The usage of digital input filter is indicated for environments susceptible to high electromagnetic interference levels to the defined in the standard IEC 61131-2 or due to special features of used sensor.

**Wire gauge:** Crimp terminals for 0.5 mm<sup>2</sup> wire in each way respecting as described at Nexto Series User Manual - MU214600.

## 5.2. Standards and Certifications

Standards and Certifications	
<b>IEC</b>	61131-2: Industrial-process measurement and control - Programmable controllers - Part 2: Equipment requirements and tests
<b>CE</b>	2014/30/EU (EMC) 2014/35/EU (LVD) 2011/65/EU and 2015/863/EU (ROHS)
<b>UK CA</b>	S.I. 2016 No. 1091 (EMC) S.I. 2016 No. 1101 (Safety) S.I. 2012 No. 3032 (ROHS)
<b>cUL US LISTED</b>	UL/cUL Listed – UL 61010-1 UL 61010-2-201 (file E473496)
<b>EAC</b>	TR 004/2011 (LVD) CU TR 020/2011 (EMC)

Table 4: Standards and Certifications

## 5.3. Compatibility with Other Products

The following table provides information regarding the compatibility of the module NJ1001 and other Nexto Series products.

NJ1001		Compatible Software Version			
Version	Revision	NX3004	NX30x0	NX5110	MasterTool IEC XE
1.2.0.4 or higher	AA or higher	1.5.1.0 or higher	1.5.1.0 or higher	1.1.1.0 or higher	2.03 or higher

Table 5: Compatibility with Other Products

**Note:**

**Revision:** If the software is upgraded in the field the product revision indicated on the label will no longer match the actual revision of the product.

**ATTENTION**

The CPUs, racks and the PROFIBUS remote head of Nexto Series support the use of Nexto Jet Modules. The Nexto Jet is formed by I/Os modules and when used in configuration with CPUs or PROFIBUS remote head of Nexto Series, no other I/O type of Nexto Series can be used in the same bus.

### 5.4. Physical Dimensions

Dimensions in mm.

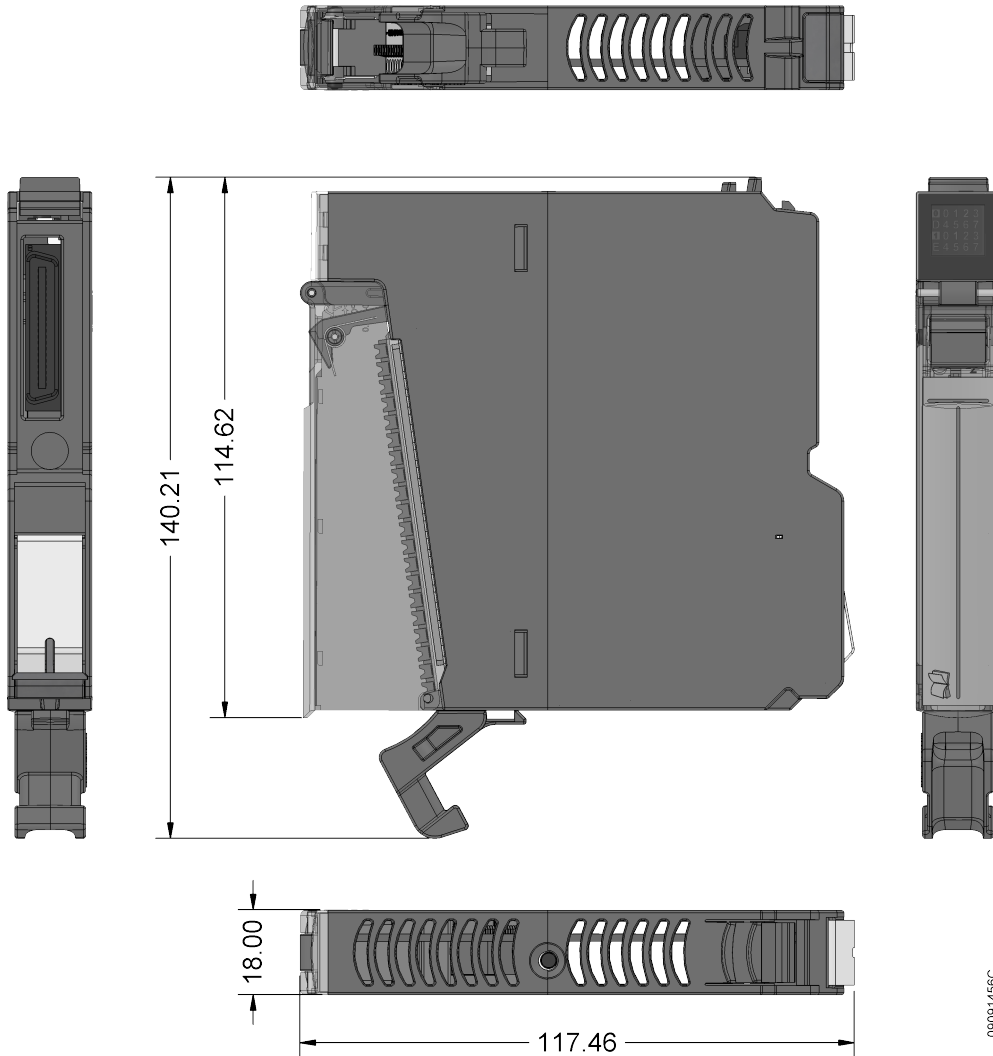

Figure 1: Physical Dimensions

## 6. Installation

For the correct installation of this product, it is necessary to use a rack (backplane rack) and it must be carried out according to the mechanical and electrical installation instructions that follow.

### 6.1. Product Identification

This product has some parts that must be observed before installation and use. The following figure identifies each of these parts.

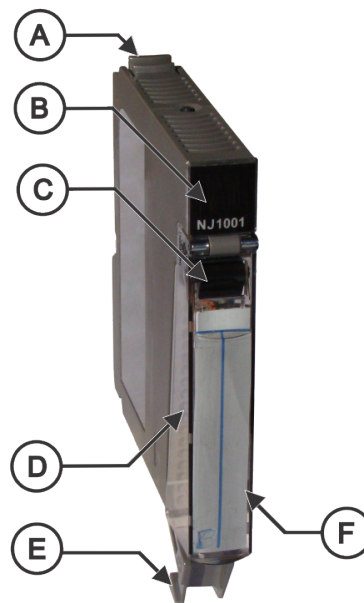

Figure 2: NJ1001

- Ⓐ Fixing lock.
- Ⓑ Status and diagnostic display.
- Ⓒ Terminal block extraction lever.
- Ⓓ Front cover.
- Ⓔ 20 pin terminal block with wire holder.
- Ⓕ Label for module identification.

The product has in its mechanics a label that identifies it and in it are presented some symbols whose meaning is described below:

 Attention! Before using the equipment and installing, read the documentation.

 Direct Current.

## 6.2. Electrical Installation

The figure below shows an example where NJ1001 is used as sink or source inputs. The inputs 00 to 03 and 10 to 13 are used as sink inputs while inputs 04 to 07 and 14 to 17 are used as source inputs. Each input group is isolated.

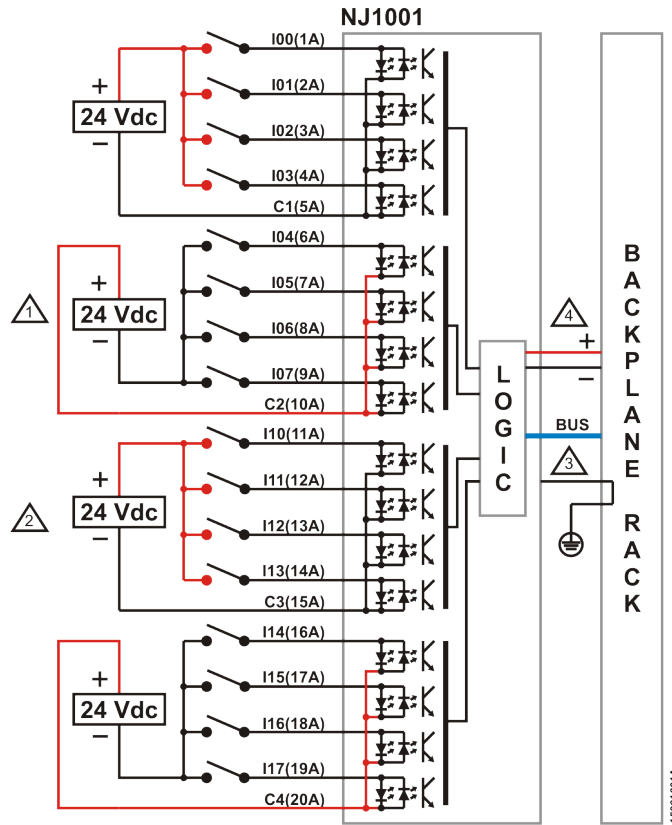

Figure 3: Electric Diagram

### Diagram Notes:

- ① Typical usage of source digital inputs, C2 is the +24 Vdc common to input group I04 to I07.
- ② Typical usage of sink digital inputs, C3 is the 0 Vdc common to input group I10 to I13.
- ③ The module is grounded through the Nexto Series backplane racks.
- ④ The module power supply is derived from the connection to the backplane rack, not requiring external connections.
- ⊕ Protection earth terminal.

### 6.3. Connector Pinout

The following table shows the function of each connector terminal:

Terminal Number	Description
1	Input 00
2	Input 01
3	Input 02
4	Input 03
5	Common for inputs 00 to 03
6	Input 04
7	Input 05
8	Input 06
9	Input 07
10	Common for inputs 04 to 07
11	Input 10
12	Input 11
13	Input 12
14	Input 13
15	Common for inputs 10 to 13
16	Input 14
17	Input 15
18	Input 16
19	Input 17
20	Common for inputs 14 to 17

Table 6: Connector Pinout

### 6.4. Mechanical and Electrical Assembly

The mechanical and electrical mounting and the connector insertion and removing for single hardware width I/O modules are described at Nexto Series User Manual - MU214600.

**ATTENTION**

Products with broken warranty seal are not covered in warranty.

**CAUTION**



The device is sensitive to static electricity (ESD). Always touch in a metallic grounded object before handling it.

**DANGER**



Nexto Series can operate with voltage up to 250 Vac. Special care must be taken during the installation, which should only be done by qualified technical personnel. Do not touch on the wiring field when in operation.



## 7. Configuration

This module was developed to be used with Nexto Series products. All Nexto Series products are configured in MasterTool IEC XE. All configuration data of a given module can be accessed through a double click in it on the Graphical Editor.

### 7.1. Process Data

Process Data, when available, are the variables that are used to access and control the module. The list below describes all variables delivered by NJ1001.

The process data of the module, when inserted in a PROFIBUS network, can be accessed through variables. The NJ1001 module has two bytes to access the input data.

Besides this data, NJ1001 also provides a set of variables containing information related to diagnostics which are also described in this document.

Variable	Size	Process Data	Description	Type	Update
%IB(n)	BYTE	Digital Inputs - Byte 0	Input value of channel 00 to 07	Input (Read)	Always
%IB(n+1)	BYTE	Digital Inputs - Byte 1	Input value of channel 10 to 17	Input (Read)	Always

Table 7: Process Data

**Note:**

**Update:** The field Update indicates if the respective process data is updated by CPU and NJ1001. When defined as Always, it means that the process data is always updated. When defined as Selectable, means that the user can select if the respective process data will be updated or not. All these process data are exchanged between CPU and NJ1001 through the bus, to improve CPU performance, it's recommended to update only the process data that will be used in the application.

### 7.2. Module Parameters

Name	Description	Options	Standard value
Input Filter Enable Mask	Enables or disables input filter feature per channel	False True	False
Input Filter Time Constant	Sets input filter time constant (ms)	2 - 255	7
%Q Start Address of Module Diagnostics Area	Defines the start address of the module diagnostics	-	-

Table 8: Module Parameters

**Notes:**

**Input Filter Enable Mask:** The field can be selected by the user to enable the input filter feature in a specific channel. If the input filter is enabled in a channel, the module will reject pulses smaller than the time configured in the Input Filter Time Constant.

**Input Filter Time Constant:** The field determines the time to apply in the filter and this parameter can be set from 2 to 255 ms.

## 8. Usage

### 8.1. General Purpose Input Read



NJ1001 has two variables to access its inputs (Digital Inputs - Byte 0 and Digital Inputs - Byte 1). Both variables have eight bits where each bit represents the physical input state of a given input channel. The relationship between each bit and its respective input can be found on the Bus I/O Mapping tab.

## 9. Maintenance

Altus recommends that all modules' connections should be checked and any dust or any kind of dirt located in the module's enclosure should be removed at least every 6 months.

This module offers important features to assist users during the maintenance: Status and Diagnostics Indicators, Web Page with Complete Status and Diagnostics List, and Diagnostics Mapped to Variables.

### 9.1. Status and Diagnostics Indicators

Nexto I/O modules have a display with the following symbols: D, E,  and numerical characters. The states of the symbols D, E,  and  are common for all Nexto Series I/O modules. These states can be consulted in the table below.

#### 9.1.1. D and E States

D	E	Description	Cause	Solution	Priority
Off	Off	Display failure or module off	<ul style="list-style-type: none"> <li>- Module disconnected;</li> <li>- External power supply failure;</li> <li>- Hardware failure.</li> </ul>	Check: <ul style="list-style-type: none"> <li>- If the module is completely connected to the rack;</li> <li>- If the rack is powered by an external source;</li> <li>- If the module has external power.</li> </ul>	-
On	Off	Normal use	-	-	9 (Lower)
Blinking 1x	Off	Active diagnostics	There is at least one active diagnostic related to the module.	Check what the active diagnostic is. More information can be found at section <a href="#">Diagnostics Through Variables</a> .	8
Blinking 2x	Off	No I/O data update	<ul style="list-style-type: none"> <li>- CPU in STOP mode;</li> <li>- Head/Remote in non-ACTIVE state.</li> </ul>	Check: <ul style="list-style-type: none"> <li>- If the CPU is in operation;</li> <li>- If the Fieldbus Master is in operation;</li> <li>- The integrity of the network between the MODBUS Client and the Head/Remote.</li> </ul>	7
Blinking 3x	Off	Reserved	-	-	6

D	E	Description	Cause	Solution	Priority
Blinking 4x	Off	Non-fatal fault	Failure in some hardware or software component, which does not have impact on the basic functionality of the product.	Check the module's diagnostic information. If it is a hardware failure, have the part replaced. If it's software, contact Technical Support.	5
Off	Blinking 2x	Loss of bus master	Loss of communication between: <ul style="list-style-type: none"> <li>- The module and the CPU;</li> <li>- The module and the Head/Remote;</li> <li>- The Head/Remote and the Field Network Master.</li> </ul>	Check: <ul style="list-style-type: none"> <li>- If the module is completely connected to the rack;</li> <li>- If the CPU is in RUN mode;</li> <li>- If the Fieldbus Master is in operation;</li> <li>- Network integrity between PROFIBUS Master and Head/Remote.</li> </ul>	4
Off	Blinking 3x	Module without calibration	<ul style="list-style-type: none"> <li>- The module is not calibrated;</li> <li>- There was an error with the calibration value.</li> </ul>	The module must return to the manufacturer.	3
Off	Blinking 1x	Missing or parameterization error	The module isn't parameterized.	Check: <ul style="list-style-type: none"> <li>- If the module parameterization is correct;</li> <li>- Network integrity between PROFIBUS Master and Head/Remote;</li> <li>- Network integrity between PROFINET Controller and Head/Remote.</li> </ul>	2
Off	Blinking 4x	Fatal hardware fault	Hardware fault.	The module must return to the manufacturer.	1 (Higher)

Table 9: Status of Symbols D and E

**Notes:**

**Field net master:** There are different field net solutions, using different nomenclatures to refer to the net master. Examples: Profibus Master, MODBUS Client, PROFINET Controller, etc.

**Module without calibration:** Only valid for modules that have calibration, typically analog modules. Modules that do not have calibration will never show such an indication through the symbols D and E.

### 9.1.2. 0, 1 and Numerical Characters

The meaning of the numerical characters can be different for specific modules. In case of digital input modules, the numerical characters represent its physical state as well. When the numerical character is on, the respective input is also on, and if the numerical character is off, the respective input is also off. The relationship between the input number and its respective numerical character can be found on the following figure.

The segments ④ and ⑤ are used to group the numerical characters used for the 16 inputs. The numerical characters that are placed at the right side of character ④ represent the inputs from 00 to 07, where character 0 is related to input 00 and character 7 is related to input 07. In the same way the numerical characters that are placed at the right side of character ⑤ represent the inputs from 10 to 17, where character 0 is related to input 10 and the character 7 is related to input 17. The figure below shows the relation between numerical characters and the respective inputs.

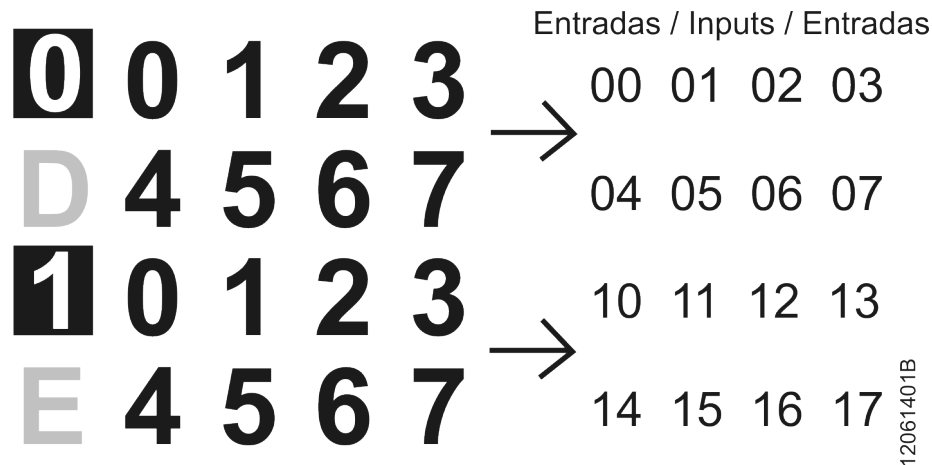

Figure 4: Display

## 9.2. Web Page with Complete Status and Diagnostics List

Another way to access diagnostics information on Nexto Series is via web pages. Nexto Series CPU's has an embedded web page server that provides all Nexto status and diagnostics information, which can be accessed using a simple browser.

More information about web page with complete status and diagnostics list can be found at User Manual of each respective CPU (listed at Nexto Series User Manual - MU214600).

## 9.3. Diagnostics Through Variables

All diagnostics in this module can be accessed through variables that can be handled by the user application or even forwarded to a supervisory system using a communication channel. There are two different ways to access diagnostics in the user application: using symbolic variables with AT directive or addressing memory. Altus recommends use symbolic variables for diagnostic accessing. The table below shows all available diagnostics for this module and their respective memory address, description, symbolic variable and string that will be shown on the CPU graphical display and web.

9.3.1. General Diagnostics

Direct Variable		Diagnostic Message	Symbolic Variable DG_NJ1001.tGeneral.*	Description	PROFIBUS Message Code
Variable	Bit				
%QB(n)	0..7	Reserved			
%QB(n+1)	0	MODULE W/ DIAGNOSTIC	bActiveDiagnostics	TRUE – Module has active diagnostics	-
		NO DIAG		FALSE – Module doesn't have active diagnostic	
	1	MODULE W/ FATAL ERROR	bFatalError	TRUE – Fatal error	25
		-		FALSE – No fatal error	
	2	CONFIG. MISMATCH	bConfigMismatch	TRUE – Parameterization error	26
		-		FALSE – Parameterization ok	
	3	WATCHDOG ERROR	bWatchdogError	TRUE – Watchdog has been detected	27
		-		FALSE – No watchdog	
	4..7	Reserved			

Table 10: General Diagnostics

Notes:

**Direct Representation Variable:** "n" is the address defined in the field %Q Start Address of Module Diagnostics Area on the NJ1001's configuration screen – Module Parameters tab in the MasterTool IEC XE.

**Symbolic Variable:** Some symbolic variables serve to access diagnostics. These diagnostics are stored in the direct representation variable, then the AT directive is used to map the symbolic variables in the direct representation variable. The directive AT is a reserved word in the MasterTool IEC XE, that uses this directive to declare the diagnostics automatically on a symbolic variables. All symbolic variables declared automatically can be found in the diagnostics object.

## 10. Manuals

For further technical details, configuration, installation and programming, the table below should be consulted.

The table below is only a guide of some relevant documents that can be useful during the use, maintenance, and programming of this product.

<b>Code</b>	<b>Description</b>	<b>Language</b>
<b>CE114000</b>	Nexto Series – Technical Characteristics	English
<b>CT114000</b>	Série Nexto – Características Técnicas	Portuguese
<b>CS114000</b>	Serie Nexto – Características Técnicas	Spanish
<b>MU214600</b>	Nexto Series User Manual	English
<b>MU214000</b>	Manual de Utilização Série Nexto	Portuguese
<b>MU299609</b>	MasterTool IEC XE User Manual	English
<b>MU299048</b>	Manual de Utilização MasterTool IEC XE	Portuguese
<b>MP399609</b>	MasterTool IEC XE Programming Manual	English
<b>MP399048</b>	Manual de Programação MasterTool IEC XE	Portuguese
<b>MU214608</b>	Nexto PROFIBUS-DP Head Utilization Manual	English
<b>MU214108</b>	Manual de Utilização da Cabeça PROFIBUS-DP Nexto	Portuguese

Table 11: Related Documents