

## 1. Product Description

The automation of electric power systems is characterized by the use of robust, reliable, and high-tech equipment and devices with the ability to operate in hostile environments, where there are significant levels of electromagnetic interference and exposure to higher operating temperatures. This is the reality of applications in hydroelectric power plants (HPPs), electricity substations, and wind farms, among others.

In this context, the Hadron Xtorm Series is an innovative Remote Terminal Unit (RTU), perfect for applications in electricity generation, transmission, and distribution. The Series has an ideal set of features with high performance and facilities for the various stages in the life cycle of an application, to reduce engineering, installation, and commissioning costs and minimize downtime and system maintenance when in operation. With intuitive and user-friendly interfaces, precise and intelligent diagnostics, a modern and robust design, and several innovative features, Hadron Xtorm exceeds the requirements of applications in this market.

The Series has an intelligent and versatile architecture, offering modularity in input and output (I/O) points, redundancy options, hot-swapping of modules, high-speed communication protocols such as IEC 61850 and DNP3, implementation of logic in compliance with the IEC 61131-3 standard and time synchronization.

The Series has a smart and versatile architecture, offering modularity in input and output (I/O) points, redundancy options, module hot swapping, high-speed communication protocols, such as IEC 61850 and DNP3, logic implementation in accordance to IEC 61131-3 standard and time synchronism. The HX2xxx output modules from Hadron Xtorm Series offers 16 relay outputs with dry contact.



Its main features are:

- 16 relay output points with dry contact NO
- CBO (Check Before Operate) operation selectable for 8 output points (HX2300 and HX2320)
- Display for module diagnostics and output state indication
- Hot swap support
- Mechanical design with high robustness and extended operating temperature
- High immunity to electromagnetic noise (EMC/EMI)
- Intelligent diagnostics such as One Touch Diag and Electronic Tag on Display

## 2. Ordering Information

### 2.1. Included Items

The product package contains the following items:

- HX2200, HX2300 or HX2320 module
- Four connectors with 10 terminals HX9402

### 2.2. Product Code

The following codes should be used to purchase the product:

Code	Description
HX2200	16 DO Relay Module
HX2300	16 DO 24 Vdc Relay Module w/ 8 CBO
HX2300/16CBO	16 DO 24 Vdc Relay Module w/ 16 CBO
HX2320	16 DO 125 Vdc Relay Module w/ 8 CBO

Table 1: Product Code

## 3. Related Products

The following products must be purchased separately when necessary:

Code	Description
NX9402	10 pin terminal block

Table 2: Related Products

## 4. Innovative Features

Hadron Xtorm Series brings to the user several innovations in utilization, supervision and system maintenance. These features were developed focusing a new concept in automation of hydropower plants, substations and other applications of the segment. The list below shows some new features that the user will find in Hadron Xtorm Series:



**One Touch Diag:** One Touch Diag is an exclusive feature that Nexto Series brings to PLCs. With this new concept, the user can check diagnostic information of any module present in the system directly on CPU's graphic display with one single press in the diagnostic switch of the respective module. OTD is a powerful diagnostic tool that can be used offline (without supervisor or programmer), reducing maintenance and commissioning times.

**ETD – Electronic Tag on Display:** Another exclusive feature that Nexto Series brings to PLCs is the Electronic Tag on Display. This new functionality brings the process of checking the tag names of any I/O pin or module used in the system directly to the CPU's graphic display. Along with this information, the user can check the description, as well. This feature is extremely useful during maintenance and troubleshooting procedures.

## 5. Product Features

### 5.1. General Features

	HX2200	HX2300/16CBO	HX2300	HX2320
<b>Module type</b>	16 digital outputs			
<b>Output type</b>	Relay output NO type			
<b>Check Before Operate Function (CBO)</b>	No	Yes, always enabled on all 16 outputs	Selectable for 8 outputs and without CBO for the others	Selectable for 8 outputs and without CBO for the others. available for modules with product revision AF or greater.
<b>Outputs with selection option for Check Before Operate function (CBO)</b>	-		02, 03, 06, 07, 12, 13, 16 e 17	
<b>Make Capacity</b>	30 A for 200 ms			
<b>Switching capacity for inductive load</b>	1,5 A @ 24 Vdc (L/R = 40 ms) 0,3 A @ 125 Vdc (L/R = 40 ms)			
<b>Switching capacity for resistive load</b>	5 A @ 24 Vdc 0,8 A @ 48 Vdc 0,7 A @ 60 Vdc 0,3 A @ 125 Vdc 0,2 A @ 240 Vdc 5 A @ 250 Vac			
<b>Voltage levels for CBO operation</b>	-	19,2 to 30 Vdc for logic level 1 0 to 5 Vdc for logic level 0		100 to 150 Vdc for logic level 1 0 to 35 Vdc for logic level 0
<b>Equivalent minimum impedance between open relay contacts with the Check Before Operate Function (CBO)</b>	-	5,6 kΩ		39 kΩ
<b>Maximum load resistance for CBO operation</b>	-	220 Ω @ 19,2 Vdc 2,2 kΩ @ 24 Vdc		5,6kΩ @ 100 Vdc 22 kΩ @ 115 Vdc 33 kΩ @ 125 Vdc
<b>Expected lifetime</b>	10 <sup>5</sup> operations for resistive loads			
<b>Maximum contact resistance</b>	100 mΩ			
<b>Switching time or outputs update</b>	Up to 10 ms			
<b>Maximum switching frequency</b>	1 Hz			
<b>Output state indication</b>	Yes			
<b>One Touch Diag (OTD)</b>	Yes			
<b>Electronic Tag on Display (ETD)</b>	Yes			
<b>Status and diagnostic indication</b>	Display, web pages and CPU's internal memory			
<b>Hot swap capability</b>	Yes			
<b>Isolation</b>				
<b>Output to logic</b>	2500 Vac / 1 minute			
<b>Outputs to protective earth</b> 	2500 Vac / 1 minute			

	HX2200	HX2300/16CBO	HX2300	HX2320
Logic to protective earth⊕	2500 Vac / 1 minute			
Current consumption from blackplane rack power supply	980 mA			
Maximum power dissipation	8 W			
Wire section	0,5 to 1,5 mm <sup>2</sup>			
Protection index	IP 20			
Operating temperature	-5 to 70 °C			
Storage temperature	-25 to 85 °C			
Operating and storage relative humidity	5 to 96 %, non-condensing			
Conformal coating	Yes			
Module dimensions (W x H x D)	38,0 x 235,3 x 187,2 mm			
Package dimensions (W x H x D)	55,0 x 308,0 x 266,0 mm			
Weight	1100 g			
Weight with package	1400 g			

Table 3: General Features

**Notes:**

**Output type:** For additional information, see the [Installation](#) section.

**Check Before Operate (CBO) function:** Allows the monitoring of the output circuitry. The HX2300 and HX2320 modules provide up to 8 relay outputs with the Check Before Operate (CBO) function, which can be enabled by an external connection. For further information, see sections Installation of the respective module and the Check Before Operate (CBO) Function on this document.

**Make Capacity:** Make capacity is the maximum current that the relay can withstand during the first 200 ms after switching the same.

**Equivalent minimum impedance between open relay contacts with the Check Before Operate (CBO) Function:** The value of the residual voltage present on the output can be calculated by voltage divider between the load resistance and the equivalent minimum impedance between contacts.

**Maximum load resistance for CBO operation:** This module has an internal digital input in parallel with the relay contact, used to predict defects in output circuits, monitoring them before operation. For more information see the Check Before Operate (CBO) section in this document.

**Conformal coating:** Conformal coating protects the electronic components inside the product from moisture, dust and other harsh elements to electronic circuits.

## 5.2. Standards and Certifications

Standards and Certifications	
<b>IEC</b>	61131-2: Industrial-process measurement and control - Programmable controllers - Part 2: Equipment requirements and tests
<b>CE</b>	2014/30/EU (EMC) 2014/35/EU (LVD) 2011/65/EU and 2015/863/EU (ROHS)
<b>UK CA</b>	S.I. 2016 No. 1091 (EMC) S.I. 2016 No. 1101 (Safety) S.I. 2012 No. 1101 (ROHS)
<b>EAC</b>	TR 004/2011 (LVD) CU TR 020/2011 (EMC)

Table 4: Standards and Certifications

## 5.3. Compatibility with Other Products

The modules HX2200 and HX2300 are supported by MasterTool Xtorm only from version 1.03 onward.

## 6. Physical Dimensions

Dimensions in mm.

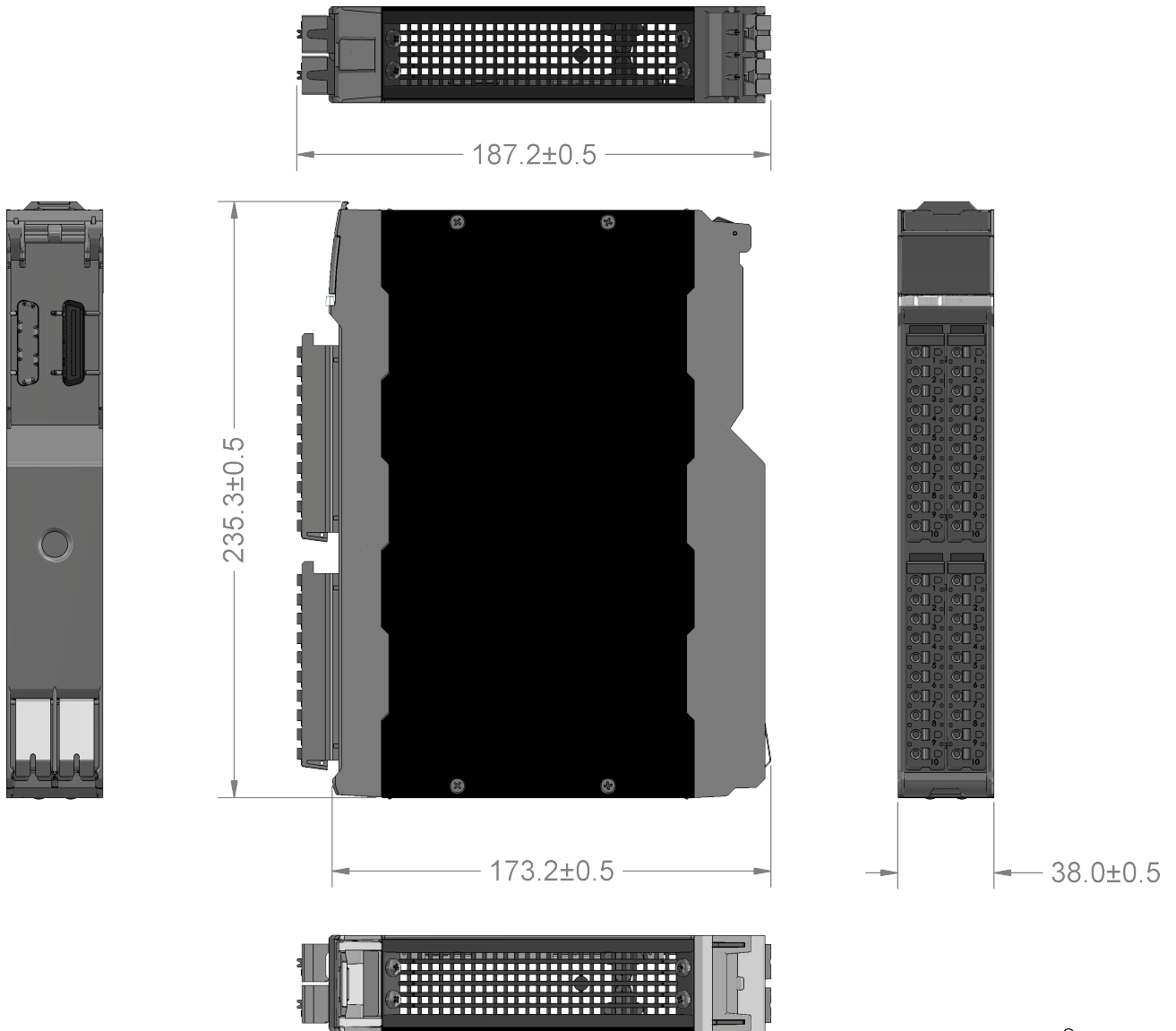

12080801D

Figure 1: Physical Dimensions

## 7. Installation

For the correct installation of this product, it is necessary to use a rack (backplane rack) and it must be carried out according to the mechanical and electrical installation instructions that follow.

### 7.1. Product Identification

This product has some parts that must be observed before installation and use. The following figure identifies each of these parts.

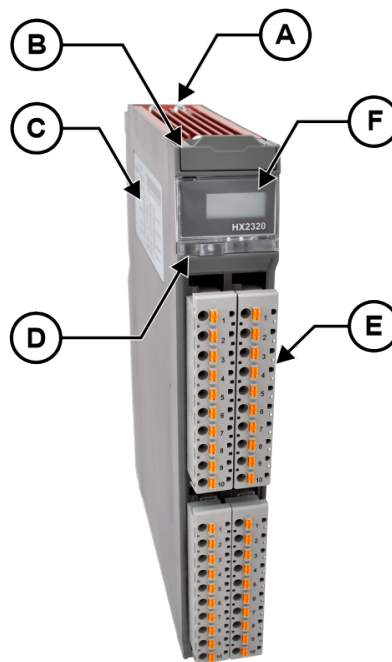

Figure 2: HX2xxx

- Ⓐ Fixing lock.
- Ⓑ Module Slot locking slider
- Ⓒ Label for module identification.
- Ⓓ Diagnostic LED and switch.
- Ⓔ 10 pin terminal blocks.
- Ⓕ Status and diagnostic display.

The product has in its mechanics a label that identifies it and in it are presented some symbols whose meaning is described below:



Attention! Before using the equipment and installing, read the documentation.



Direct Current.

**7.2. Electrical Installation**

**7.3. Electrical Installation HX2200**

The figure below shows an example where each HX2200 module output is connected to the load. The outputs 00 to 03 are showing an example of digital output connection using a single external power supply to a group of digital outputs. The digital outputs 04 to 07, 10 to 13 and 14 to 17 show an example of dry contact connection, where each output has its own power supply, as shown below.

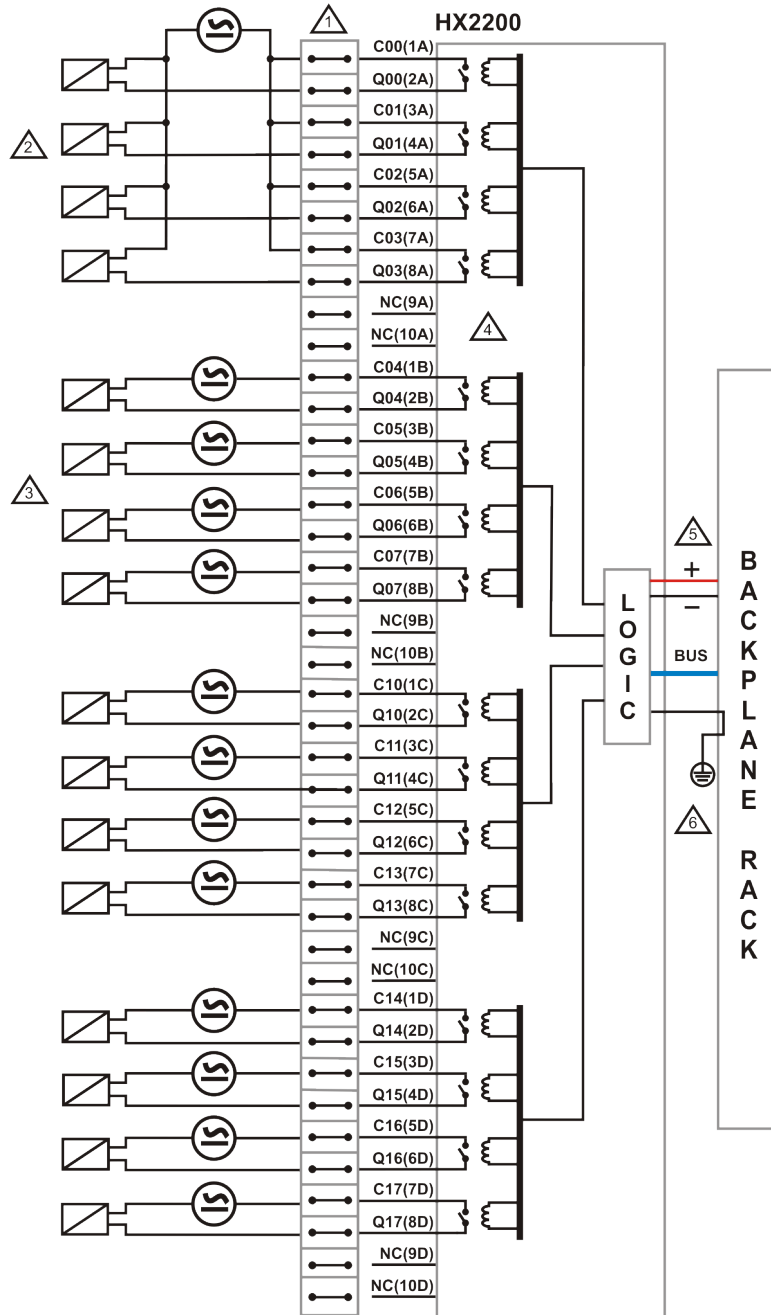

Figure 3: Diagram for connecting the Digital Outputs



**Notes:**

- ① Set of terminals.
- ② Typical usage of digital output using the load power supply to a group of digital outputs.
- ③ Typical usage of dry contact digital output using the load power supply to each one of the outputs.
- ④ Unused terminals in HX2200 module.
- ⑤ The module power supply is derived from the connection to the backplane rack, not requiring external connections.
- ⑥ The module HX2200 is grounded  $\ominus$  through the backplane.

### 7.3.1. Connector Pinout HX2200

The figure below indicates the position of the connectors A, B, C and D.

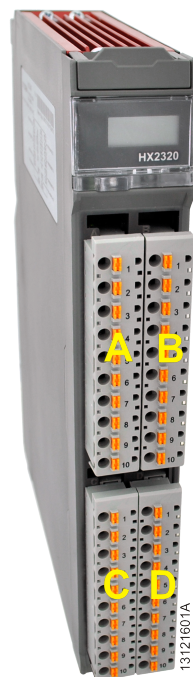

Figure 4: Connector Pinout

The following table shows the description of each terminal:

A	Terminal	B
Description	Number	Description
Output 00 (Common)	1	Output 04 (Common)
Output 00	2	Output 04
Output 01 (Common)	3	Output 05 (Common)
Output 01	4	Output 05
Output 02 (Common)	5	Output 06 (Common)
Output 02	6	Output 06
Output 03 (Common)	7	Output 07 (Common)
Output 03	8	Output 07
Not connected	9	Not connected
Not connected	10	Not connected
C	Terminal	D
Description	Number	Description
Output 10 (Common)	1	Output 14 (Common)
Output 10	2	Output 14
Output 11 (Common)	3	Output 15 (Common)
Output 11	4	Output 15
Output 12 (Common)	5	Output 16 (Common)
Output 12	6	Output 16
Output 13 (Common)	7	Output 17 (Common)
Output 13	8	Output 17
Not connected	9	Not connected
Not connected	10	Not connected

Table 5: Connector Pinout HX2200

**Note:**

The points of the output module are independent (dry contact). Therefore, there is no polarity in the connection with external load.

### 7.4. Electrical Installation HX2300 and HX2320

The figure below shows an example where each HX2300/HX2320 module output is connected to the load.

The outputs 00 to 03 are showing an example of digital output connection using a single external power supply to a group of digital outputs. The digital outputs 04 to 07, 10, 11, 14 and 15 show an example of dry contact connection, where each output has its own power supply.

The outputs 12 and 13 show an example where each output has its own power supply and optional monitoring through the connection indicated by the dotted line. The outputs 16 and 17 show an example where each output has its own power supply and optional monitoring through the connection indicated by the dotted line, with a resistor in parallel with the load.

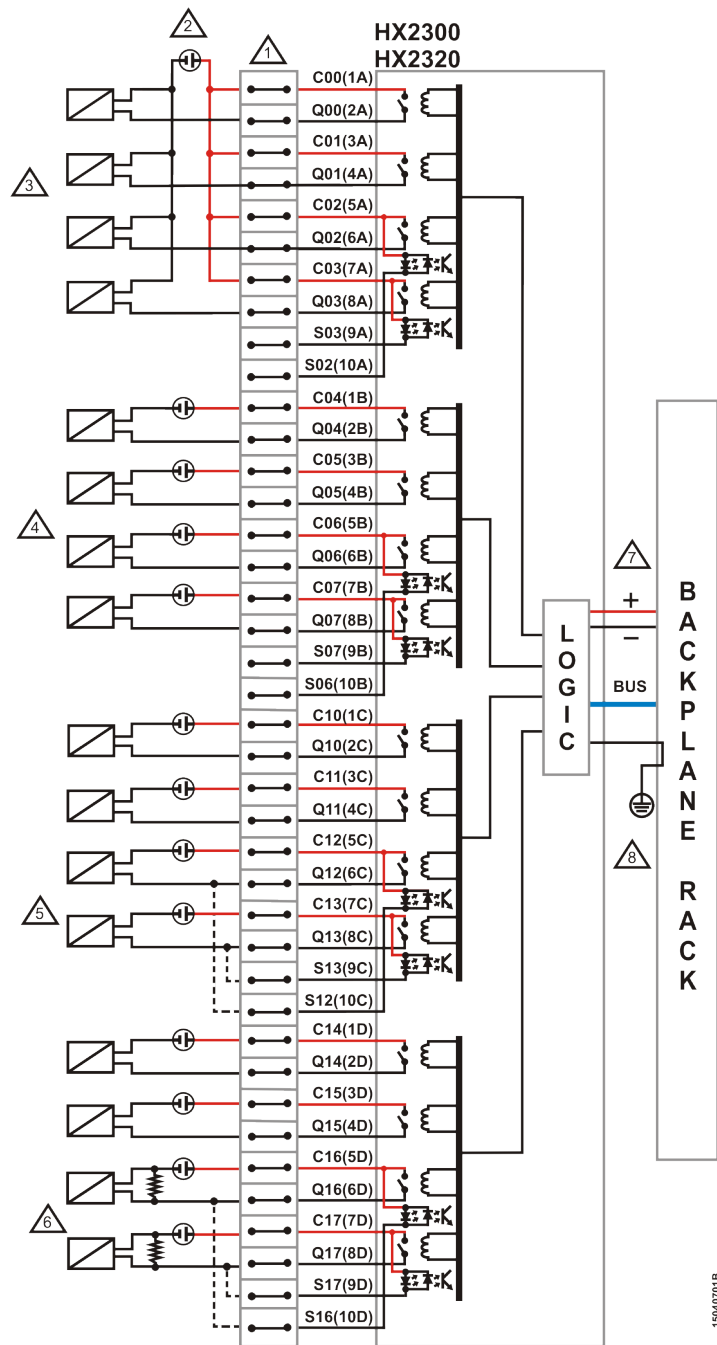

Figure 5: Diagram for connecting the Digital Outputs

## Notes:

- ① Set of terminals.
- ② The nominal voltage for the load power supply is 24 Vdc for HX2300 and 125 Vdc for HX2320.
- ③ Typical usage of digital output using the load power supply to a group of digital outputs.
- ④ Typical usage of dry contact digital output using the load power supply to each one of the outputs.
- ⑤ Typical usage of dry contact digital output with optional monitoring (CBO function), indicated through the dotted line.
- ⑥ Typical usage of dry contact digital output and optional monitoring (CBO function), indicated through the dotted line, and with a resistor in parallel with the load. This resistor is used to adjust the residual voltage over the load (which is created by the equivalent impedance present between the relay contacts) and also to adjust the load impedance to respect the maximum value for operation of CBO circuit.
- ⑦ The module power supply comes through the backplane and does not require external connections.
- ⑧ The module HX2300/HX2320 is connected to the protection earth  $\oplus$  through the backplane.

### 7.4.1. Connector Pinout HX2300/HX2320

The figure below indicates the position of the connectors A, B, C and D.

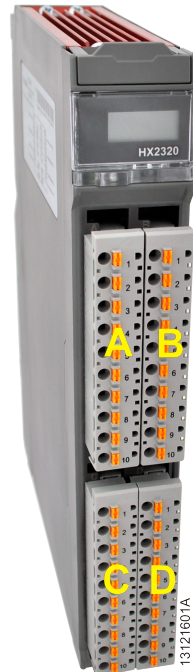

Figure 6: Connector Pinout

The following table shows the description of each terminal:

A	Terminal Number	B
<b>Description</b>		<b>Description</b>
Output 00 (Commom)	1	Output 04 (Commom)
Output 00	2	Output 04
Output 01 (Commom)	3	Output 05 (Commom)
Output 01	4	Output 05
Output 02 (Commom)	5	Output 06 (Commom)
Output 02	6	Output 06
Output 03 (Commom)	7	Output 07 (Commom)
Output 03	8	Output 07
Output Status 03	9	Output Status 06
Output Status 02	10	Output Status 07
C	Terminal Number	D
<b>Description</b>		<b>Description</b>
Output 10 (Commom)	1	Output 14 (Commom)
Output 10	2	Output 14
Output 11 (Commom)	3	Output 15 (Commom)
Output 11	4	Output 15
Output 12 (Commom)	5	Output 16 (Commom)
Output 12	6	Output 16
Output 13 (Commom)	7	Output 17 (Commom)
Output 13	8	Output 17
Output Status 13	9	Output Status 16
Output Status 12	10	Output Status 17

Table 6: Connector Pinout HX2300/HX2320

**Note:**

The points of the output module are independent (dry contact). Therefore, there is no polarity in the connection with external load.

## 7.5. Electrical Installation HX2300/16CBO

The figure below shows an example where each output of the HX2300/16CBO module is directed to a load. Outputs 00 to 03 show an example of a digital output connection using a single external power supply for a group of digital outputs. Digital outputs 04 to 07 and 14 to 17 show an example of a dry contact type connection, where each output has its power supply. Outputs 10 to 13 show an example of a connection where each output has its power supply and, in parallel with the load, a resistor is used when the impedance of the load to be driven is minimal, as shown below.

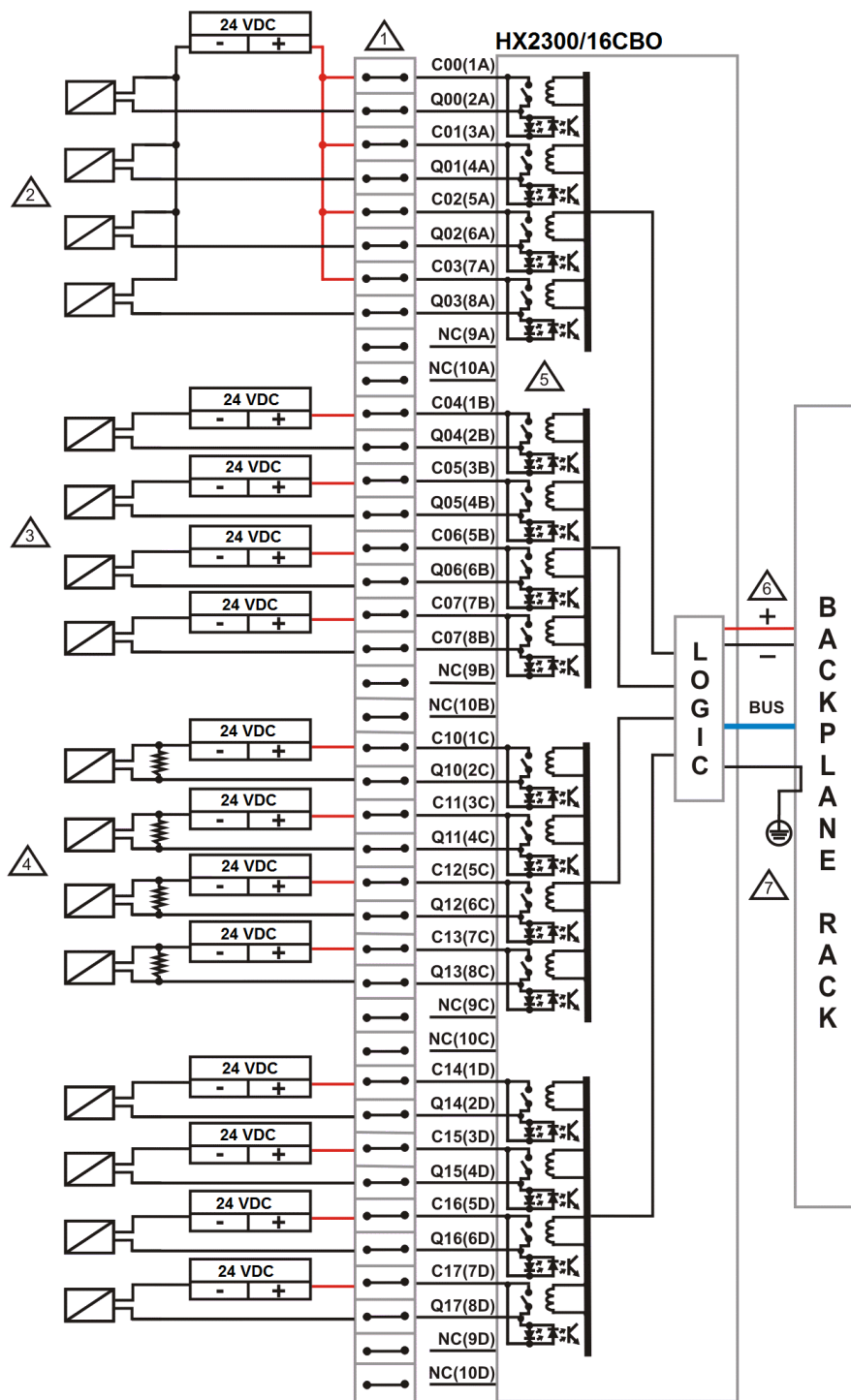

Figure 7: Diagram for connecting the Digital Outputs

**Notes:**

- ① Set of terminals.
- ② Typical usage of digital output using the load power supply to a group of digital outputs.
- ③ Typical usage of dry contact digital output using the load power supply to each one of the outputs.
- ④ Typical use of a dry contact digital output, with a resistor in parallel with the load when the load has a very high impedance, which is insufficient for the BOD monitoring circuit.
- ⑤ Unused terminals in HX2300/16CBO module.
- ⑥ The module power supply is derived from the connection to the backplane rack, not requiring external connections.
- ⑦ The module HX2300/16CBO is grounded  $\oplus$  through the backplane.

### 7.5.1. Connector Pinout HX2300/16CBO

The figure below indicates the position of the connectors A, B, C and D.

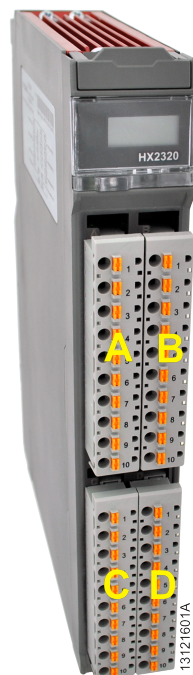

Figure 8: Connector Pinout

The following table shows the description of each terminal:

<b>A</b>	<b>Terminal Number</b>	<b>B</b>
<b>Description</b>		<b>Description</b>
Output 00 (Commom)	1	Output 04 (Commom)
Output 00	2	Output 04
Output 01 (Commom)	3	Output 05 (Commom)
Output 01	4	Output 05
Output 02 (Commom)	5	Output 06 (Commom)
Output 02	6	Output 06
Output 03 (Commom)	7	Output 07 (Commom)
Output 03	8	Output 07
Not connected	9	Not connected
Not connected	10	Not connected
<b>C</b>	<b>Terminal Number</b>	<b>D</b>
<b>Description</b>		<b>Description</b>
Output 10 (Commom)	1	Output 14 (Commom)
Output 10	2	Output 14
Output 11 (Commom)	3	Output 15 (Commom)
Output 11	4	Output 15
Output 12 (Commom)	5	Output 16 (Commom)
Output 12	6	Output 16
Output 13 (Commom)	7	Output 17 (Commom)
Output 13	8	Output 17
Not connected	9	Not connected
Not connected	10	Not connected

Table 7: Connector Pinout HX2300/16CBO

**Note:**

The points of the output module are independent (dry contact). Therefore, there is no polarity in the connection with external load.

**7.6. Protection Circuit**

For further information, consult the "Lightning Protection" section of the Hadron Xtorm Utilization Manual - MU223600.

**ATTENTION**

Atmospheric discharges (thunders) may cause damages to the product although its protections. Additional protections should be used if the product's power comes from a power supply located outside the panel where it is installed because it could be vulnerable to this kind of discharges. If the field wiring of the output points is susceptible to this kind of discharge, surge suppressors should be used.



## 7.7. Mechanical Assembly

The mechanical and electrical mounting and the connector insertion or removal in I/O modules is described in the Hadron Xtorm Utilization Manual - MU223600.

### ATTENTION

Products with broken warranty seal are not covered in warranty.

### CAUTION



The device is sensitive to static electricity (ESD). Always touch in a metallic grounded object before handling it.

### DANGER



Hadron Xtorm Series can operate with voltage up to 250 Vac. Special care must be taken during the installation, which should only be performed by qualified technical personnel. Do not touch the field wiring when in operation.

## 8. Configuration

The HX2xxx modules were developed to be used with Hadron Xtorm Series products. All products in the Hadron Xtorm Series are configurable in MasterTool Xtorm. All configuration data of a given module can be accessed through a double click in the desired module on the Graphical Editor.

### 8.1. Process Data

The process data, when available, are the variables used to access and control the module. The table below shows all the variables delivered by HX2xxx modules. Besides this data, the module also provides a set of variables containing information related to diagnostics which are also described in this document.

Process Data	Description	Type
Digital Outputs Byte-0	Output value of channel 00 to 07	Output (Read / Write)
Digital Outputs Byte-1	Output value of channel 10 to 17	Output (Read / Write)

Table 8: Process Data

## 9. Utilization

### 9.1. General Purpose Output Writing

The HX2xxx modules have two variables to control their outputs (Digital Outputs Byte-0 and Digital Outputs Byte-1). These variables have 8 bits where each bit represents the output logical state of each output channel. The relationship between each bit and its respective output can be found on the Bus tab: *I/O Mapping*.

### ATTENTION

The outputs are disabled and will to secure state (off) when the module recognizes a master loss or when the CPU goes to STOP mode.

## 9.2. Double Points Mapping

Double point's mappings are used to map digital double points to the digital output modules. This type of mapping is used to indicate the position of equipment such as valves, circuit breakers and disconnect switches where the transition between the open and closed states require a certain time, thus indicate an intermediate state of transition between the two final states. The relationship between the logic outputs and logic points are shown in the following table.

Mapping	Logic Output	Logic Point
Byte-0	00	0
	01	
	02	1
	03	
	04	2
	05	
	06	3
	07	
Byte-1	10	4
	11	
	12	5
	13	
	14	6
	15	
	16	7
	17	

Table 9: Double Points Mapping

The variables to be used for the double points mapping must be declared using the type DBP.

In the case of points mapped as double points, the variable "ON" (variablename.ON) should be mapped into an odd number output of the module, and the variable "OFF" (variablename.OFF) should be mapped into an even number output of the module as shown in the following figure:

Variable	Mapping	Channel	Address	Type	Unit	Description
		Digital Outputs - Byte 0	%QB0	BYTE		Output state.
		Output 00	%QX0.0	BOOL		
		Output 01	%QX0.1	BOOL		
		Output 02	%QX0.2	BOOL		
		Output 03	%QX0.3	BOOL		
		Output 04	%QX0.4	BOOL		
		Output 05	%QX0.5	BOOL		
Application.CommandReceiverIO.dbpDoublePointIO.OFF		Output 06	%QX0.6	BOOL		
Application.CommandReceiverIO.dbpDoublePointIO.ON		Output 07	%QX0.7	BOOL		
		Digital Outputs - Byte 1	%QB1	BYTE		Output state.

Figure 9: Double Points Mapping

The use of this type of mapping can be done through the PulsedCommand function, which performs the access to the variables mapped as double points. For each one of the points, the function generates a pulse in the output according to the parameters passed to the function, and returns a point status variable.

The following line shows the PulsedCommand function syntax with a configuration example:

```
byresult := PulsedCommand(byCommandType := 101, byRackNumber := 0,
    bySlotNumber :=4, byPairIndex := 3,byPulseTime := 10);
```

The parameters that should be passed to the function are described in the table below:

Name	Type	Options	Description
byCommandType	Byte	102 101 100	Definition of the command type to be passed to the function: 102 – TRIP command (Off) 101 – CLOSE command (On) 100 – Returns the output status
byRackNumber	Byte	0 to 31	Number of the rack where the module is connected
bySlotNumber	Byte	According to the size of the rack chosen for the project	Slot number of the rack where the module is connected
byPairIndex	Byte	0 to 7	Index of pair
byPulseTime	Byte	2 to 255	Pulse time in one-hundredth of a second

Table 10: PulsedCommand Function Parameters

The function can return any of the status values listed in the following table:

Function status (Byte)	Description
1	Invalid command type
2	Pulse time passed to the function is outside the range
3	The point passed to the function is not a double point, or the point does not exist in the specified module
4	Module did not respond to the command
5	The function returns this code when accepts the command and starts executing it
6	There is already an active command at this double point
7	The command was terminated

Table 11: PulsedCommand Function Status

### 9.3. Check Before Operate Function (CBO)

The *Check Before Operate function (CBO)* is a logic that allows the detection of defects in the output circuits, monitoring them before starting operation. The CBO is required in power generation/distribution equipment for greater reliability. This function can be enabled for the outputs 02, 03, 06, 07, 12, 13, 16 and 17 of the HX2320 and HX2300 modules as described on the Figure present in the [Electrical Installation](#) section of the respective module on this document.

The monitoring is done in the main loop of the module, being possible to identify three types of faults in the output module. They are called Disconnected Load, Power failure for load activation and Relay failure (or failure in the CBO monitoring circuit). The failure detection time, from the moment the failure was originated until the moment the Status became active, is equal to the module diagnostics update time, and the user should take into account this time to develop his programming logic using the CBO functionality. For each output there is a status variable which value may be TRUE or FALSE. The table below presents the relationship between the state of each output point (Off or On), the value of the respective status variable (FALSE or TRUE) and the defects in the output circuit.

Output Point State	Symbolic variable DG_modulename.tDetailed .bStatusOutput_XX	Description	Cause
Off	FALSE	Output circuit failure	Load disconnected or power failure for load activation
Off	TRUE	No output circuit failure	-
On	FALSE	No output circuit failure	-
On	TRUE	Output circuit failure	Relay or CBO monitoring circuit failure

Table 12: Relationship between Status and Output of the Check Before Operate Function

**Note:**

The value of the status variable does not block the normal operation of the respective output point. It is just an indication of a possible failure in the drive circuit. If the problem that leads to the status changing is resolved, the status variable returns to its previous value to the occurrence of the failure.

## 10. Maintenance

Altus recommends that all modules connections must be checked and that all dust or any kind of dirt located at the module’s enclosure must be removed at least every 6 months.

The HX2xxx modules offer five important features to assist users during maintenance: Electronic Tag on Display, One Touch Diag, Status and Diagnostics Indicators, Web Page with Complete Status and Diagnostics List and Status and Diagnostics Mapped to Variables.

### 10.1. Electronic Tag on Display e One Touch Diag

Electronic Tag on Display and One Touch Diag are important features that provide to the user the option to check the tag, description and diagnostics related to a given module directly on the CPU display.

To check the tag and diagnostics of a given module, it’s required only one short press on its diagnostic switch. After pressing once, CPU will show the tag and the module diagnostics. To access the respective module description just long press the diagnostic switch of the respective module.

More information on Electronic Tag on Display can be found at the Hadron Xtorm Utilization Manual - MU223600.

### 10.2. Status and Diagnostics Indicators

The HX2xxx modules of Hadron Xtorm Series have a display and a bi-color LED to represent the diagnostics with the following symbols: D, E,  and numerical characters. The states of the symbols D and E are common for all Hadron Xtorm Series slaves modules; these states can be consulted in the table below. The same D and E symbol states are indicated by the color of the LED in module front panel.

The meaning of the numerical characters may be different for specific modules.

## 10.2.1. Status of Symbols D, E and Diagnostic LED (DL)

Symbol D	Symbol E	DL (Color)	Description	Cause	Solution	Priority
Off	Off	Off	Display fail, module off or OTD fail	Disconnected module. No external supply or hardware fail	Check if the module is completely connected to the backplane rack and if the backplane rack is supplied by an external power supply	-
On	Off	On (Blue)	Normal use	-	-	7 (Lower)
Blinking 1x	Off	Blinking 1x (Blue)	Active Diagnostics	There is at least one active diagnostic related to HX6000 module	Check what the active diagnosis is. More information can be found in the <a href="#">Maintenance</a> section of this document	6
Blinking 2x	Off	Blinking 2x (Blue)	CPU in STOP mode	CPU in STOP mode	Check if CPU is in RUN mode. More information can be found on CPU's documentation	5
Blinking 4x	Off	Blinking 4x (Blue)	Hardware non-fatal error	Hardware fault	The module remains with its main functionality, but in order to correct the fault, Altus support team must be contacted	4
Off	Blinking 1x	Blinking 1x (Red)	Parameterization Error	The module isn't parameterized or received an invalid parameter	Check if the module parameterization is correct	2
Off	Blinking 2x	Blinking 2x (Red)	Loss of master	Loss of communication between module and CPU	Check if the module is completely connected to the backplane rack. Check if CPU is in RUN mode	3
Off	Blinking 4x	Blinking 4x (Red)	Hardware fatal error	Hardware fault	Contact Altus support team in case of hardware fatal error	1 (Higher)

Table 13: D, E and Diagnostics LED (DL) States

## 10.2.2. 0, 1 and Numerical Characters

The segments 0 and 1 are used to group the numerical characters used for the 16 outputs. The characters that are placed at the right side of character 0 represent the outputs from 00 to 07, where character 0 represents the outputs 00 and character 7 represents the outputs 07. Similarly, characters that are placed at the right side of character 1 represent the outputs from 10 to 17, where character 0 represents the output 10 and character 7 represents the output 17. The figure below shows the relationship between the numerical characters and the respective outputs.

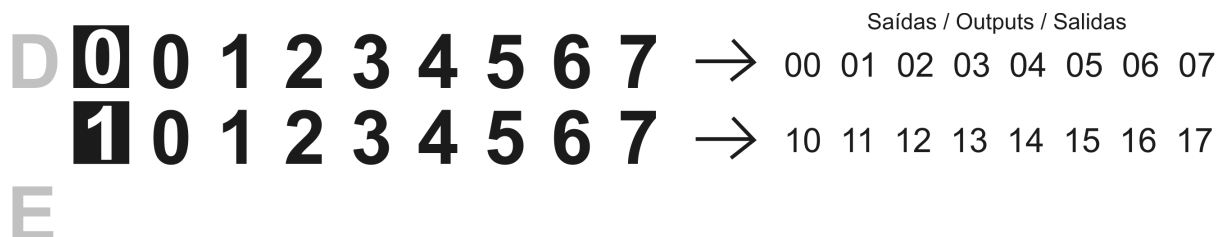

12101503A

Figure 10: Display

## 10.3. Web Page with Complete Status and Diagnostics List

Another way to access diagnostic information on Hadron Xtorm Series is via web pages. Hadron Xtorm Series CPU's has an embedded web pages server that provides all status and diagnostic information, which can be accessed using a simple browser.

More information about web page with complete status and diagnostic list can be found at Hadron Xtorm Utilization Manual - MU223600.

## 10.4. Diagnostics Mapped through Variables

All the diagnostics of the HX2xxx modules can be accessed through symbolic variables that can be handled by the user application or even mapped to a supervisory using a communication channel. The table below shows all available diagnostics for the HX2xxx modules and their respective symbolic variables, description and string that will be shown on the CPU Graphical Display and Web.

### 10.4.1. General Diagnostics

Diagnostic Message	Symbolic Variable DG_modulename.tGeneral.	Description
<b>UNKNOWN DIAGNOSTIC</b>	bReserved_08..15	Reserved
<b>MODULE W/ DIAGNOSIS</b>	bActiveDiagnostics	<b>TRUE</b> – Module has active diagnostics
<b>NO DIAG</b>		<b>FALSE</b> – Module doesn't have active diagnostics
<b>MODULE W/ FATAL ERROR</b>	bFatalError	<b>TRUE</b> – Fatal error <b>FALSE</b> – No fatal error
<b>CONFIG. MISMATCH</b>	bConfigMismatch	<b>TRUE</b> – Parameterization error <b>FALSE</b> – Parameterization ok
<b>WATCHDOG ERROR</b>	bWatchdogError	<b>TRUE</b> – Watchdog has been detected <b>FALSE</b> – No watchdog detected
<b>OTD SWITCH ERROR</b>	bOTDSwitchError	<b>TRUE</b> – Failure on the diagnostic switch <b>FALSE</b> – No failure on the diagnostic switch

Diagnostic Message	Symbolic Variable DG_modulename.tGeneral.	Description
<b>UNKNOWN DIAGNOSTIC</b>	bReserved_05..06	Reserved
<b>BUS COM. ERROR</b>	bCommunicationError	<b>TRUE</b> – Failure in module communication with the bus <b>FALSE</b> – Module communication with the bus is OK

Table 14: General Diagnostics

## 10.4.2. Detailed Diagnostics

Diagnostic Message	Symbolic Variable DG_modulename.tDetailed.	Description
Status of Output 00	bStatusOutput_00	See Note
Status of Output 01	bStatusOutput_01	See Note
Status of Output 02	bStatusOutput_02	See Note
Status of Output 03	bStatusOutput_03	See Note
Status of Output 04	bStatusOutput_04	See Note
Status of Output 04	bStatusOutput_05	See Note
Status of Output 06	bStatusOutput_06	See Note
Status of Output 07	bStatusOutput_07	See Note
Status of Output 10	bStatusOutput_10	See Note
Status of Output 11	bStatusOutput_11	See Note
Status of Output 12	bStatusOutput_12	See Note
Status of Output 13	bStatusOutput_13	See Note
Status of Output 14	bStatusOutput_14	See Note
Status of Output 15	bStatusOutput_15	See Note
Status of Output 16	bStatusOutput_16	See Note
Status of Output 17	bStatusOutput_17	See Note

Table 15: Detailed Diagnostics

**Note:**

**bStatusOutput\_XX:** The status variable will assume the value FALSE when the respective output does not have the Check Before Operate Function (CBO). On the other hand, the outputs that have the Check Before Operate Function (CBO) enabled will indicate values TRUE and FALSE according to the description of section [Check Before Operate Function \(CBO\)](#).

## 10.5. Hot Swap

These products supports hot swap. For more information about how to correctly perform a hot swap, see the Hadron Xtorm Utilization Manual – MU223600.

## 11. Manuals

For further technical details, configuration, installation and programming of Hadron Xtorm Series, the table below should be consulted.

The table below is only a guide of some relevant documents that can be useful during the use and maintenance of HX2xxx modules. The complete and updated table containing all documents of Hadron Xtorm Series can be found at the Hadron Xtorm Utilization Manual – MU223600.

<b>Code</b>	<b>Description</b>	<b>Language</b>
<b>CE123000</b>	Hadron Xtorm Series Technical Characteristics	English
<b>CT123000</b>	Características Técnicas Série Hadron Xtorm	Portuguese
<b>MU223600</b>	Hadron Xtorm Utilization Manual	English
<b>MU223000</b>	Manual de Utilização Hadron Xtorm	Portuguese

Table 16: Related Documents